

IN THIS ISSUE...

COVER ARTICLE

New 16-Bit SO-8 DAC Has 1LSB Max INL and DNL Over Industrial Temperature 1

Jim Brubaker and William C. Rempfer

Issue Highlight 2

LTC® in the News 2

DESIGN FEATURES

The LT®1374: New 500kHz, 4.5A Monolithic Buck Converter 5
Karl Edwards

The LT1581 Low Dropout Regulator Provides 10 Amps of Output Current 8
Todd Owen

The LT1370: New 500kHz, 6A Monolithic Boost Converter 11
Karl Edwards

New LTC1504: Flexible, Efficient Synchronous Switching Regulator Can Source or Sink 500mA 14
Dave Dwelley

Low Dropout Regulator Driver Handles Fast Load Transients and Operates on Single 3V-10V Input 16
Lenny Hsiu

LT1579 Battery-Backup Regulator Provides Uninterruptible Power ... 18
Todd Owen

High Efficiency Distributed Power Converter Features Synchronous Rectification 21
Dale Eagar

DESIGN IDEAS

..... 25-32
(complete list on page 25)

DESIGN INFORMATION

Reference Squeezes More Performance from Less Package 33
John Wright

LTC1659, LTC1448: Smallest Rail-to-Rail 12-Bit DACs Have Lowest Power 34
Hassan Malik

LTC1197/LTC1199: New Micropower MSOP 10-Bit ADC Samples at 500ksps 35
Guy Hoover and Marco Pan

New Device Cameos 37

Design Tools 39

Sales Offices 40

New 16-Bit SO-8 DAC Has 1LSB Max INL and DNL Over Industrial Temperature

by Jim Brubaker and William C. Rempfer

New generations of industrial systems are moving to 16 bits and hence require high performance 16-bit data converters. The new LTC1595/LTC1596 16-bit DACs from LTC provide the easiest to use, most cost effective, highest performance solution for industrial and instrumentation applications. The LTC1595/LTC1596 are serial input, 16-bit, multiplying current output DACs. Features of the new DACs include:

- ±1LSB maximum INL and DNL over the industrial temperature range
- Ultralow, 1nV-s glitch impulse
- ±10V output capability
- Small SO-8 package (LTC1595)
- Pin-compatible upgrade for industry-standard 12-bit DACs (DAC8043/8143 and AD7543)

Nice Features of the 16-Bit DACs

The LTC1595/LTC1596 use precision thin-film resistors in a modified R/2R architecture to provide a CMOS current output DAC, as shown in Figure 1. The two DACs have SPI/MICROWIRE™ compatible serial interfaces and draw only 10µA from a single 5V supply. They generate precision 0V-10V or ±10V outputs using a single or

dual external op amp. The LTC1596 has an asynchronous clear input and both devices have power-on reset.

16-Bit Accuracy Over Temperature without Autocalibration

In the past, only autocalibrated DACs could achieve 16-bit (1LSB) accuracy over temperature. Not only did this require cumbersome calibration overhead for the user but the DACs also had to be recalibrated every time the temperature changed because of the DAC's poor linearity drift. In addition, the highly complicated autocalibration circuitry made the DACs very large and very expensive.

Now there is a better choice. The LTC1595/LTC1596's ultralow linearity drift (well below ±0.2LSB from -40°C to 85°C) allows the DACs to be factory trimmed and to hold their 16-bit accuracy over time and temperature. This provides a cleaner, easier, more cost-effective solution for precision systems.

Figure 2 shows the typical integral nonlinearity (INL) and differential nonlinearity (DNL) of the LTC1595. The outstanding 0.25LSB typical values and the very low drift allow a maximum 1LSB specification to be guaranteed over the extended industrial temperature range.

continued on page 3



LT, LTC and LT are registered trademarks of Linear Technology Corporation. Adaptive Power, Burst Mode, C-Load, FilterCAD, LinearView, Micropower SwitcherCAD and SwitcherCAD are trademarks of Linear Technology Corporation. MICROWIRE is a trademark of National Semiconductor Corp. Other product names may be trademarks of the companies that manufacture the products.

Issue Highlights

The subject of our cover article this issue is the LTC1595/LTC1596 serial input, 16-bit, multiplying current output DACs. These parts feature ± 1 LSB maximum INL and DNL over the industrial temperature range, ultralow, 1nV-s glitch impulse and ± 10 V output capability. They are pin-compatible with industry-standard 12-bit DACs.

The remainder of this issue's Design Features section introduces a variety of new power products:

LT1374 is a new 4.5A buck converter designed to meet the needs of higher current and voltage applications. With its 500kHz operating frequency and integral 80m Ω switch, only a few surface mount components are required to produce a complete switching regulator. The LT1374 features current mode control, external synchronization and a low current (20 μ A typical) shutdown mode.

Another new 500kHz switcher introduced in this issue is the LT1370, a 6A boost converter. At 65m Ω on-resistance and 42V maximum switch voltage, the LT1370 can be used in a wide range of output voltage and current applications. LT1370 features include current mode operation, external synchronization and a low current shutdown mode (12 μ A typical). The LT1370 will operate in all standard switching configurations, including boost, buck, flyback, forward, inverting and SEPIC.

For even higher currents, we introduce the LT1339, the buck/boost converter that "needs no steroids." The LT1339 is ideal for power levels ranging from tens of watts to tens of kilowatts. It has an innovative slope-compensation function that allows the circuit designer freedom in controlling both the slope and offset of the slope-compensation ramp. Additionally, the LT1339 has an average current limit loop that yields a constant output current limit, regardless of input and/or output voltage.

Yet another new switcher is the LTC1504 8-pin step-down switching regulator. It consists of a 200kHz fixed frequency, voltage-feedback, buck-mode switching regulator controller and a pair of 1.5 Ω power switches in an 8-pin SO package. The LTC1504 improves functionality by integrating a synchronous rectifier on-chip, maximizing efficiency and minimizing external parts count while allowing the output to both sink and source current: it can source or sink up to 500mA with input voltages from 3.3V to 10V and output voltages as low as 1.26V.

A new low dropout NPN regulator, the LT1581, can provide up to 10 amps of output current. By using separate supplies for the control circuitry and the drive to the NPN output transistor, the dropout on the pass transistor is reduced to the saturation voltage of the transistor. This makes it is easy to obtain dropout voltages as low as 430mV at 10A of load current. The part is fully protected from overcurrent and overtemperature conditions.

Another low dropout regulator debuting this month is the LT1579 "smart regulator." The LT1579 is a dual input, single output, low dropout regulator that provides an uninterruptible output voltage from two independent input voltage sources on a priority basis. It is capable of providing 300mA from either input at a dropout voltage of 0.4V.

The LT1573 is the latest low dropout voltage regulator driver from Linear Technology. The LT1573 is designed to provide a low cost solution to applications requiring high current, low dropout and fast transient response. The LT1573 is available as an adjustable regulator with an output range of 1.27V to 6.8V, and with fixed output voltages of 2.5V, 2.8V and 3.3V. Output accuracy is better than 1% to meet the critical regulation requirements of fast microprocessors.

LTC in the News...

LTC Achieves Record Quarterly Bookings, Sales and Profits

"This was a strong summer quarter for us, as we achieved record quarterly bookings, sales and profits," explains Robert Swanson, president and CEO, based on Linear Technology's latest quarterly sales and earnings report. "We grew cash by roughly \$63 million and now have over \$500 million in cash and short-term investments. Demand was strong for our products, particularly in the communications and computer end markets. This demand should help us continue to grow in the upcoming quarter."

These comments are based on results announced on October 14, 1997. LTC had net sales for its first quarter ended September 28 of \$109,802,000—an increase of 22% over net sales of the \$90,063,000 for the first quarter of the previous year. The Company also reported record net income for the quarter of \$40,643,000 or \$0.51 per share, an increase of 30% over last year of \$31,358,000 or \$0.40 per share, reported for the first quarter of last year. A cash dividend of \$0.06 will be paid on November 12, 1997 to shareholders of record on October 24, 1997. 

The Design Ideas section of this issue features two battery-related applications: a single-cell Li-Ion battery supervisor based on the LT1496 op amp and the LT1634 precision reference, a low profile 800mA Li-Ion charger using the LT1510-5 switch-mode battery charger. Also included are a high voltage/high current bench supply, a switcher that generates two bias voltages without a transformer, a single-supply random code generator and a low distortion, low power HDSL driver.

In addition, we present design information on the LT1460 voltage reference in the SOT-23 package, the LTC1448 and LTC1659 12-bit rail-to-rail DACs and the LTC1197/LTC1199 10-bit ADCs.

We conclude with a quintet of new device cameos. 

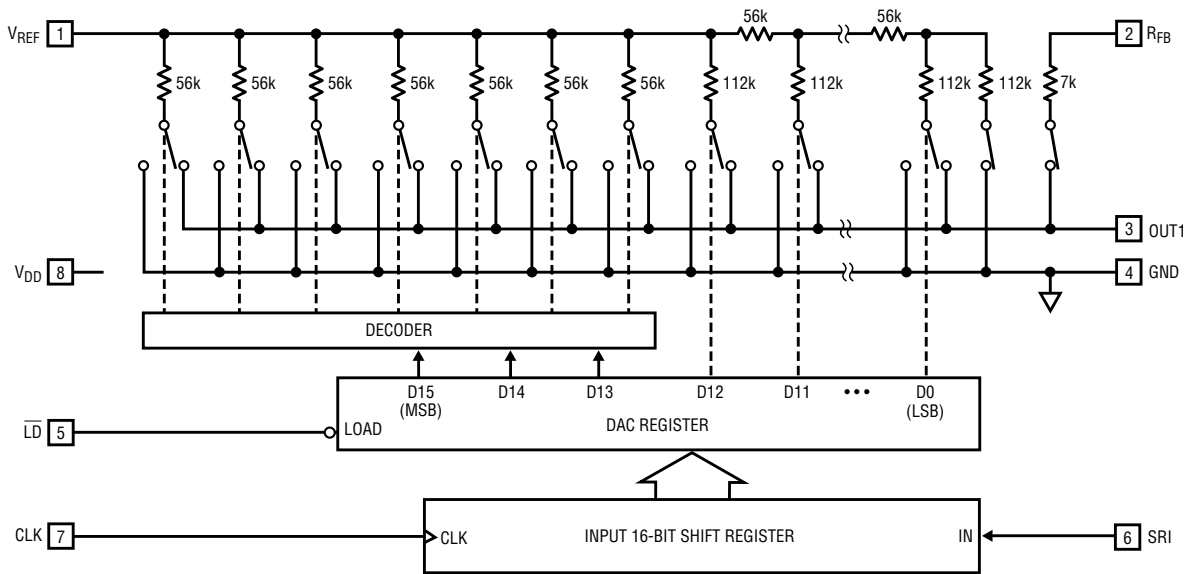

Figure 1. The LTC1595/LTC1596 16-bit CMOS DACs use a precision thin-film modified R/2R architecture to provide unsurpassed accuracy and stability. They provide a pin-compatible upgrade for industry-standard 12-bit CMOS DACs (DAC8043/8143 and AD7543).

LTC1595, continued from page 1

Ultralow 1nV-s Glitch

Glitches in a DAC's output when it updates can be a big problem in precision applications. Usually, the worst-case glitch occurs when the DAC output crosses midscale. The

LTC1595/LTC1596's new proprietary deglitcher reduces the output glitch impulse to 1nV-s, which is ten times lower than any other 16-bit industrial DAC. (1nV-s is equivalent to a glitch of 7LSBs and 1μs duration.) In addition, the deglitcher makes the glitch impulse uniform for any code. Figure 3 shows the output glitch for a midscale transition with a 0V to 10V output range.

upgraded to true 16-bit resolution and linearity without requiring more precise op amps.

0V-10V and ±10V Output Capability

Precision 0V-10V Outputs with One Op Amp

Figure 4 shows the circuit for a 0V-10V output range. The DAC uses an external reference and a single op amp in this configuration. This circuit can also perform 2-quadrant multiplication where the reference input is driven by a ±10V input signal

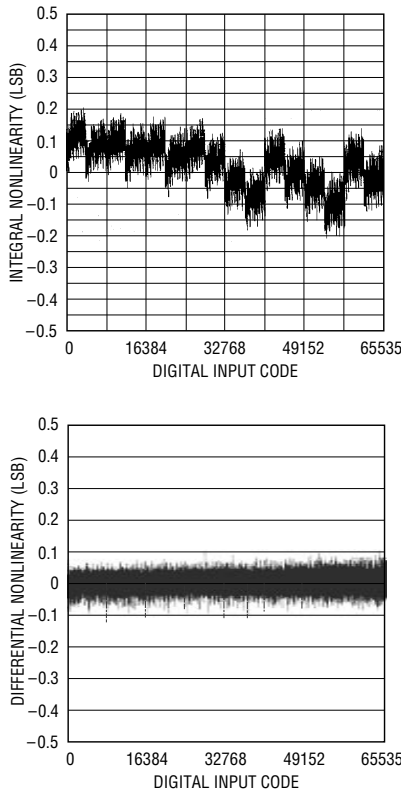

Figure 2. The outstanding INL and DNL (typically less than 0.25LSB) and very low linearity drift allow a maximum 1LSB spec to be guaranteed over industrial temperature.

Tiny Footprint: SO-8

Previous 16-bit DACs have had large packages that required large board space. The new LTC1595 breaks this trend with an SO-8 pinout. With the addition of a single output op amp (MSOP or SO-8) and a voltage reference, a complete 16-bit voltage output DAC can be constructed in a fraction of the space of previous products.

Pin-for-Pin Upgrade to Industry Standard 12-Bit DACs

An especially helpful feature for some users is the ease of upgrade to these new 16-bit devices. They directly replace the popular 12-bit DAC8043/8143 and AD7543. Because sensitivity of the LTC1595/LTC1596 INL to op amp offset voltage is reduced by five times compared to the 12-bit devices, most systems can be easily

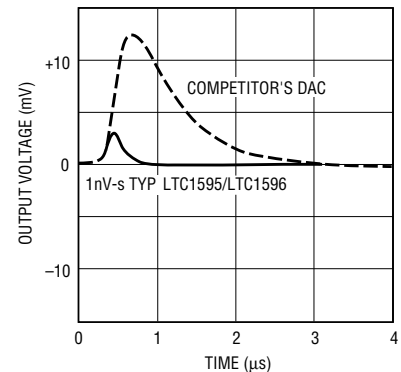

Figure 3. The proprietary deglitcher reduces the output glitch to less than 1nV-s, which is five times less than any other 16-bit industrial DAC. Further, the deglitcher makes the glitch impulse uniform, independent of code.

and V_{OUT} swings from 0V to $-V_{REF}$. The full-scale accuracy of the circuit is very precise because it is determined by precision-trimmed internal resistors. The power dissipation of the circuit is set by the op amp dissipation and the current drawn from the DAC reference input (7k nominal). The supply current of the DAC itself is less than $10\mu\text{A}$.

An advantage of the LTC1595/LTC1596 is the ability to choose the output op amp to optimize the accuracy, speed, power and cost of the application. Using an LT1001 provides excellent DC precision, low noise and low power dissipation (90mW total for Figure 4's circuit). For higher speed, an LT1007 or LT1122 can be used. The LT1122 will provide settling to 1LSB in $3\mu\text{s}$ for a full-scale transition. Figure 5 shows the $3\mu\text{s}$ settling performance obtained with

the LT1122. The feedback capacitor in Figure 4 ensures stability. In higher speed applications, it can be used to optimize transient response. In slower applications, the capacitor can be increased to reduce glitch energy and provide filtering.

Precision $\pm 10\text{V}$ Outputs with a Dual Op Amp

Figure 6 shows a bipolar, 4-quadrant multiplying application. The reference input can vary from -10V to 10V and V_{OUT} swings from $-V_{REF}$ to $+V_{REF}$. If a fixed 10V reference is used, a precision $\pm 10\text{V}$ bipolar output will result.

Unlike the unipolar circuit of Figure 4, the bipolar gain and offset will depend on the matching of the external resistors. A good way to provide good matching and save board space is to use a pack of matched 20k

resistors (the 10k unit is formed by placing two 20k resistors in parallel).

The LT1112 dual op amp is an excellent choice for high precision, low power applications that do not require high speed. The LT1124 will provide faster settling. Again, with op amp selection the user can optimize the speed, power, accuracy and cost of the application.

Conclusion: Time to Upgrade

The new LTC1595/LTC1596 provide an excellent opportunity for users to upgrade lower resolution systems to 16 bits, cleanly, easily and cost effectively. They give outstanding accuracy over temperature, ultralow glitch impulse, small footprint and low cost. For these reasons, they will improve the performance of industrial and instrumentation systems. 

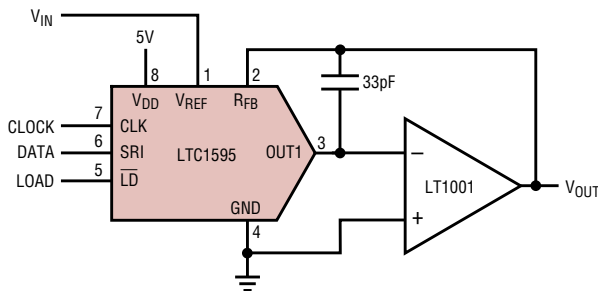

Figure 4. With a single external op amp, the DAC performs 2-quadrant multiplication with $\pm 10\text{V}$ input and 0V to $-V_{REF}$ output. With a fixed -10V reference, it provides a precision 0V- 10V unipolar output.

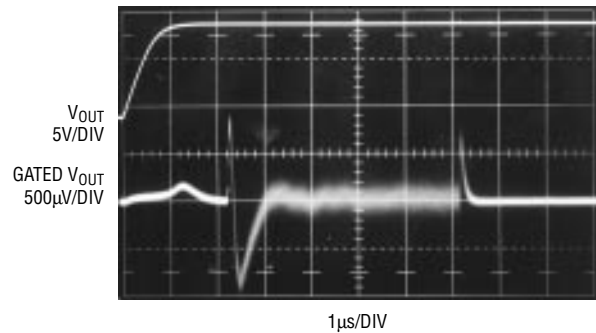

Figure 5. When used with an LT1122 (in the circuit of Figure 4), the LTC1595/LTC1596 can settle in $3\mu\text{s}$ to a full-scale step. The top trace shows the output swinging from 0V to 10V . The bottom trace shows the gated settling waveform settling to 1LSB (1/3 of a division) in $3\mu\text{s}$.

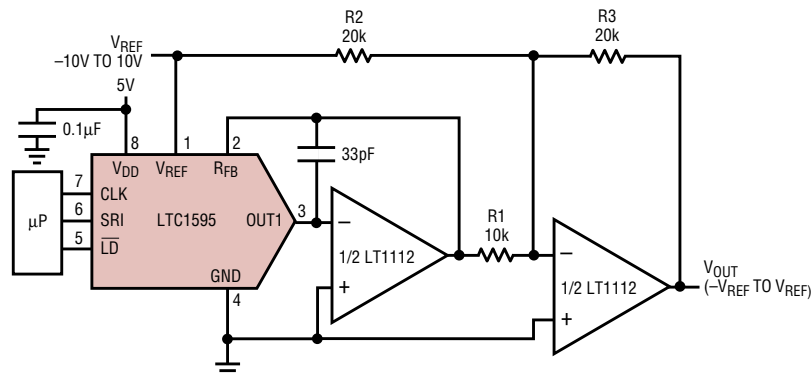

Figure 6. With a dual op amp, the DAC performs 4-quadrant multiplication. With a fixed 10V reference, it provides a $\pm 10\text{V}$ bipolar output.

The LT1374: New 500kHz, 4.5A Monolithic Buck Converter

by Karl Edwards

Introduction

Expanding on the current range of 500kHz switchers, Linear Technology introduces a new 4.5A buck converter, the LT1374. The LT1374 is the big brother of the 1.5A LT1376. Designed to meet the needs of higher current and voltage applications, it maintains high efficiency using an on-chip 80mΩ switch. With its 500kHz operating frequency and integral switch, only a few external, surface mount components are required to produce a complete switching regulator. All the features found on the LT1376 have been retained, including current mode control, external synchronization and a low current (typically 20μA) shutdown mode. Improvements have been made to

reduce start-up headroom and switching noise. A novel power device layout makes it possible to fit a high speed, bipolar, 80mΩ switch into a surface mount SO-8 package. The LT1374 is also available in DD and TO-220 packages for higher power applications.

LT1374 Features

- ❑ Constant 500kHz switching frequency
- ❑ 80mΩ high speed switch
- ❑ 20μA shutdown current
- ❑ Uses all surface mount components
- ❑ Cycle-by-cycle current limiting
- ❑ Available in SO-8 package

Circuit Description

The LT1374 is a constant-frequency, current mode buck converter. As shown in Figure 1, an internal clock and two feedback loops control the power switch. In addition to the normal output feedback error amplifier, a current sense amplifier monitors switch current on a cycle-by-cycle basis. The feedback error amplifier output, V_C , is compared to the switch-current sense output to control the trip point of the power switch. This removes the additional 90° phase shift that occurs with voltage-controlled systems, easing frequency compensation and giving a faster transient response. Nonlinear slope compensation is added to the current sense signal to prevent subharmonic oscillation.

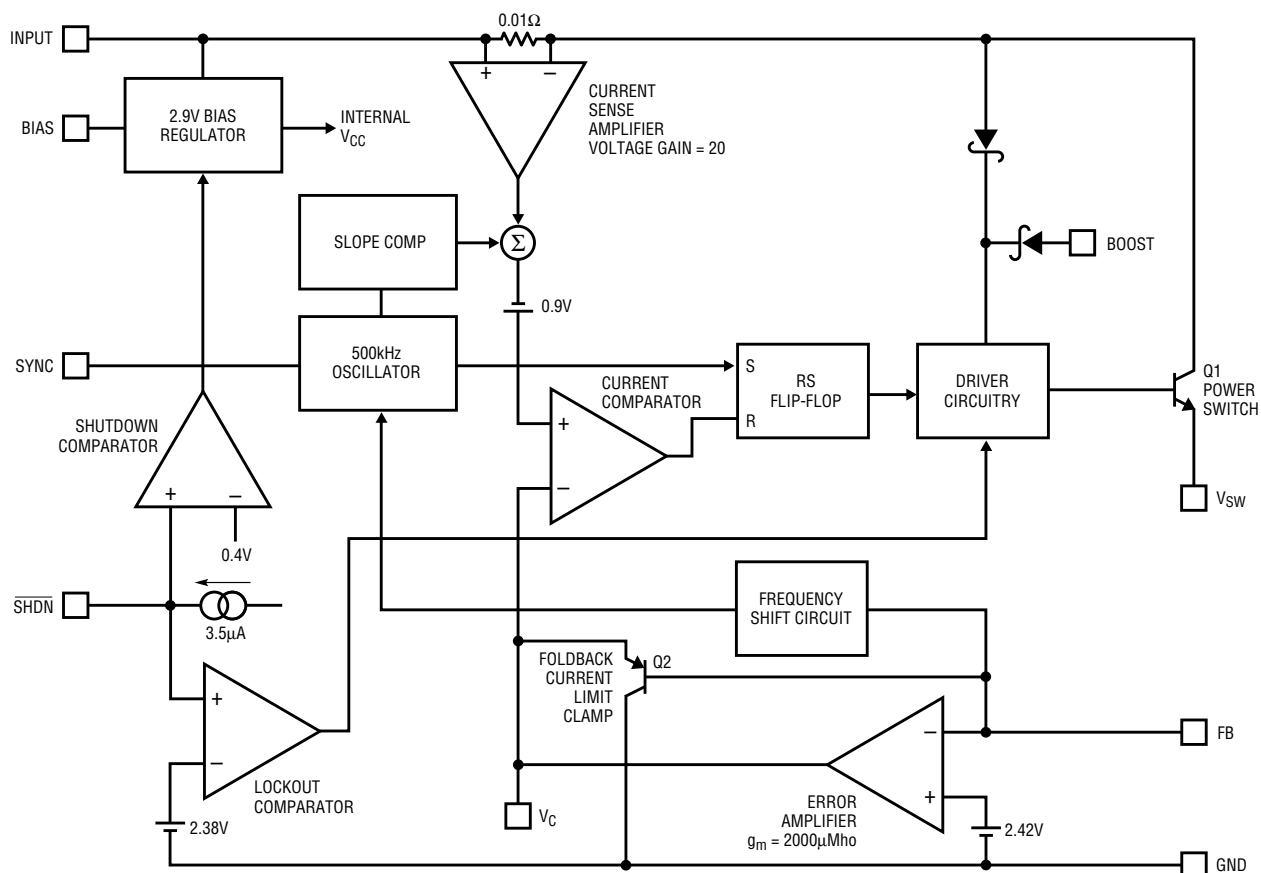

Figure 1. LT1374 block diagram

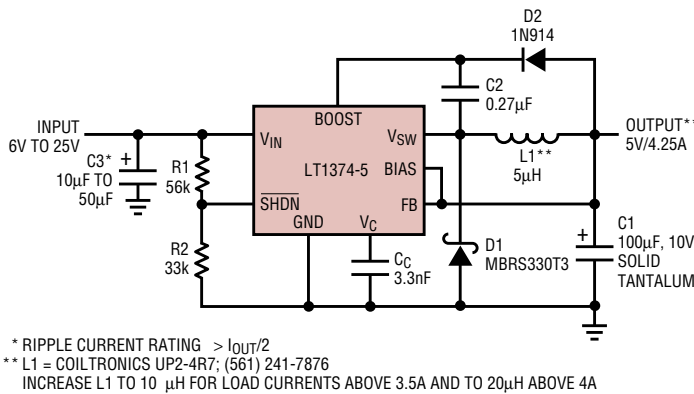

Figure 2. 5V buck converter

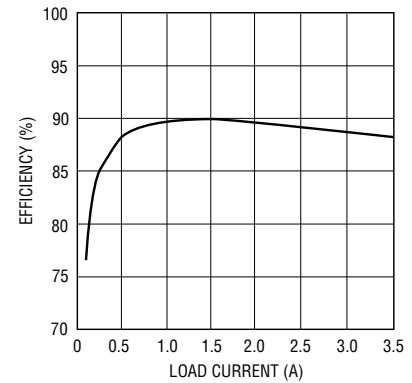

Figure 3. Efficiency: 10V in, 5V out

lation at higher duty cycles. The slope amplitude has been set to stabilize inductance values as low as 2µH. The feedback pin, FB, provides several overload protection functions. As feedback falls below 1.7V, a voltage clamp is gradually applied to the V_C pin, reducing current limit. At power-up, this performs a soft-start function. When FB is below 1V, as in the case of a shorted output, the oscillator frequency is reduced to 100kHz. Because the minimum on-time for the switch remains the same, minimum duty cycle is effectively reduced by a factor of five. This lowers power dissipation in both the LT1374 and the catch diode, D1, as shown in Figure 2.

High switch efficiency is attained by driving the switch with a voltage that is higher than the input voltage, allowing the switch to saturate. This boosted voltage is generated on the BOOST pin with an external capacitor, C2, and diode, D2 as shown in Figure 2.

The LT1374 has been improved by reducing minimum start-up voltage at low output currents, as shown in Figure 4. At low output currents, there is not enough energy in the inductor at switch-off to drive the switch-node capacitance down to ground. In this condition, the minimum start-up voltage is the unboosted voltage drop across the output switch. Improvements made to the drive circuitry of the LT1374 have reduced this drop from 2.5V on the LT1376 to 1.2V.

Additionally, the minimum boost voltage required to fully saturate the switch has been reduced to 2.3V.

Current used by the boost circuit appears as an efficiency loss; supplying this from a lower voltage, via the boost diode, D2, improves efficiency. For most applications with outputs above 3V, the configuration shown in Figure 2 will be optimal. Converters with lower output voltages should use the input or an alternative supply for the boost diode.

Switch-transition time has important effects on the usability and overall efficiency of the converter. A fast switch-transition time gives high efficiency, but it also creates EMI and RFI. Slowing the transition time of the switch reduces noise but lowers efficiency. The LT1374 operates at higher currents than the LT1376, so the same transition time would result in more noise. Because the low on-resistance of the LT1374 reduces I²R losses in the switch, a small increase in switching transition losses is an acceptable trade-off to reduce noise. The switching time for the LT1374 is 24ns, approximately 50% slower than that of the LT1376. Most of the LT1374's circuitry operates from an internally regulated 2.9V bias line. By default, the bias regulator draws power from the input pin, but if the BIAS pin is connected to an external source higher than 3V (normally V_{OUT}), bias current will be drawn from this source, improving efficiency.

An external clock signal (up to 900kHz) can be fed into the SYNC pin to increase the internal oscillator frequency or synchronize it to a system clock. The SYNC function is defeated during start-up, when FB is low, to allow correct operation of the reduced

frequency, shorted-output protection circuit. The shutdown pin has two functions, undervoltage lockout and shutdown. Below 2.38V, the switching function is disabled. With the addition of an external divider to the input (R1 and R2 in Figure 2), an undervoltage lockout can be implemented. Below 0.4V, a complete shutdown of the internal circuitry occurs, reducing supply current to 20µA.

4.5A in an SO-8

The LT1374 is available in several packages, two of which, the 7-lead DD and the SO-8, are surface mount. Thermal considerations are always important when operating surface mounted power devices without additional heat sinking. The output switch of the LT1374 has been designed to minimize power dissipation from both on-resistance and base-drive current. The SO-8 package has a fused ground lead. This lead has a solid connection to the tab to which the die is attached, providing low thermal resistance out of the package. Adding copper circuit board area around this pin can reduce junction-to-ambient thermal resistance to 80°C/W. This allows the use of the SO-8 packaged LT1374 in applications that would have previously required a TO-220. For example, a motor drive may require 4A at start-up, but only 2.5A when running. The SO-8 packaged LT1374 can provide the full 4.5A of switch current required to supply the 4A peak load. It could supply this current for several seconds due to the long thermal time

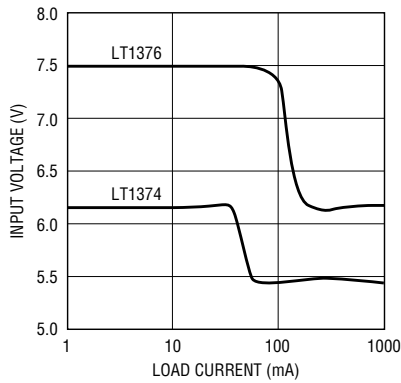

Figure 4. Minimum input voltage with 5V output

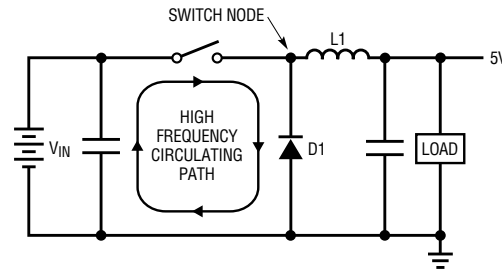

Figure 5. High speed switch path

constant of the SO-8 package. Calculating the temperature rise for 2.5A of continuous current using the circuit in Figure 2, a 12V to 5V converter, we see that power losses due to the switch resistance, switch drive current and quiescent current are 0.57W, 0.1W and 0.04W, respectively, totaling 0.71W. On a well laid-out PCB using the SO-8 package, this power dissipation would result in only a 57°C rise of die temperature, allowing the part to operate at an ambient temperature of 77°C. If 4A of continuous current is required, use the surface mounted DD package ($\theta_{JA} = 30^\circ\text{C/W}$). For even higher power, the TO-220 package ($\theta_{JC} = 4^\circ\text{C/W}$) may be used.

Application: 5V/4.25A Buck Converter

With its 25V input and 4.5A minimum switch current, the LT1374 will fit into a wide range of applications. Figure 2 shows a typical buck converter with a 6V to 25V input range, a 5V output and 4.25A of output current capability. Due to the low on-resistance of the switch, efficiency remains high over a wide range of currents, as shown in Figure 3. To reduce power dissipation, both the BIAS pin and boost circuit are supplied from the 5V output.

Several factors, including maximum current, core and copper losses, size and cost, affect the choice of inductor, L1. A high value, high current inductor gives the highest output current with the lowest ripple, at the expense of a large physical size and cost. Lower inductance values tend to

be physically smaller, have higher current ratings and are cheaper, but output ripple current, and hence ripple voltage, increases.

The input capacitor, C3, experiences very high ripple currents, up to $I_{OUT}/2$, so low ESR tantalum capacitors are needed. At 4.25A output current, two capacitors in parallel are required to meet the ripple current requirement. The ripple current in the output capacitor, C1, is lower, but its ESR still needs to be low to limit output voltage ripple. The voltage drop across the catch diode, D1, has a significant effect on overall converter efficiency, especially at higher input voltages when the switch duty cycle is low. Its ability to survive short-circuit conditions may increase its power rating. For good electrical performance, D1 must be placed close to the LT1374. The power dissipated in D1 will raise the PC board's temperature around the LT1374. This must be taken into account when modeling or taking bench measurements of die temperature.

The loop compensation capacitor, C_C , produces a pole in the frequency response at 240Hz. Unity-gain phase margin can be further improved with the addition of a resistor, typically 2k, in series with C_C , adding a zero to the frequency response. This, however, can cause a large-signal subharmonic problem in the loop. The output ripple voltage feeds back through the error amplifier to the V_C pin, changing the current trip point of the next cycle. This changes the voltage ripple at the output, and the loop is closed. Adding

a second capacitor directly from the V_C pin to ground to form a pole at one-fifth the switching frequency solves the problem.

PCB Layout

All high current, high speed circuits require careful layout to obtain optimum performance. When laying out the PCB, keep the trace length around the high frequency switching components, shown in Figure 5, as short as possible. This minimizes the EMI and RFI radiation from the loop created by this path. These traces have a parasitic inductance of approximately 20nH/inch, which can cause an additional problem at higher operating voltages. At switch-off, the current flowing in the trace inductance causes a voltage spike. This is in addition to the input voltage across the switch transistor. At higher currents, the additional voltage can potentially cause the output switching transistor to exceed its absolute maximum voltage rating.

Conclusion

With its 80m Ω on-resistance, the LT1374 makes a very compact, low parts count, high current DC/DC converter without the need for separate control and power devices. The wide selection of package outlines provides a solution for most miniature, low profile applications. A 25V, 500kHz, 4.5A switch gives the flexibility for a wide range of applications. The LT1374 complements and extends the current range of Linear's DC/DC converters. 

The LT1581 Low Dropout Regulator Provides 10 Amps of Output Current

by Todd Owen

Introduction

Improvements in microprocessors and logic devices continue to increase their speed and power. Gate dimensions continue to decrease along with the supply voltages required to power them. Unfortunately, the supply current requirements for these new logic devices are heading in the opposite direction: a larger number of gates driven at higher clock frequencies requires higher supply current. In addition, the load transients are larger and faster. Current steps from several hundred milliamperes to several amperes in tens of nanoseconds are common.

Lower supply voltages, higher supply currents and faster load transients require tighter specifications for regulators. Input/output differential voltages tend to be under 1V, supply currents can be up to 10A and transitions from no load to full load can occur in tens of nanoseconds. Low dropout PNP-based regulators can meet input/output differential specifications, but their transient load performance is less than stellar. Conventional NPN-based regulators can meet the higher load current specifications and transient needs, but dropout voltage tends to be above 1V. In addition, this higher dropout voltage specification requires the use of higher input supply voltages, leading to increased power dissipation in the regulator.

The LT1581 Solves Many Problems

The new LT1581 NPN regulator can meet the needs of many new designs. By using separate supplies for the control circuitry and the drive to the NPN output transistor, the dropout on the pass transistor is reduced to the saturation voltage of the transistor. With this approach, it is easy to obtain dropout voltages as low as

220mV at 4A, 310mV at 7A or 430mV at 10A of load current. The current requirement for the control circuitry is approximately 1/150 of the load current, or about 70mA for a 10A load. This control voltage must be at least 1.2V greater than the output to achieve these low dropout specifications. Maximum supply voltage to the power input is 7V and the maximum

Lower supply voltages, higher supply currents and faster load transients require tighter specifications for regulators. Input/output differential voltages tend to be under 1V, supply currents can be up to 10A and transitions from no load to full load can occur in tens of nanoseconds.

control voltage is 13V. The part is fully protected from overcurrent and overtemperature conditions. Fixed output voltage and adjustable versions are available in a 7-pin TO-220 package.

Both fixed and adjustable versions of the LT1581 have remote-sense pins, permitting very accurate regulation of output voltage at the load, where it counts, rather than at the regulator. Typical load regulation is only 1mV for a 2.5V output over a 100mA to 10A range. The adjust pin is brought out on the fixed voltage version of the part. This allows for the addition of a small bypass capacitor on the feedback divider, greatly improving transient response. A capacitor value of 0.1 μ F to approximately 1 μ F will generally provide optimum transient response. Additionally, reference

accuracy has been improved to a guaranteed 0.6% tolerance. The part can easily hold 1% output accuracy over temperature, guaranteed, while operating with an input/output differential voltage of well under 1V.

Careful design has eliminated any supply sequencing issues associated with a dual-supply system. The output is inhibited until both input supplies are operating. If the control voltage reaches a quiescent state first, the output current will be limited to a few milliamperes until the power input voltage stabilizes. If the power input comes up first, the output will not turn on at all until the control voltage reaches a quiescent state. The output can never turn on unregulated. The LT1581 can also be operated as a single-supply device by tying the control and power inputs together. Dropout in single supply operation is essentially the same as would be expected in a conventional NPN-based low dropout regulator.

All of these features add together to make a part with excellent static and dynamic specifications. Additionally, the low dropout voltage solves a problem many designers have been faced with: power dissipation. Lowering the input/output differential voltage translates directly to reduced power dissipation in the regulator. Care must be exercised regarding board layout and thermal management if the full performance capability of the LT1581 is to be achieved.

Layout Considerations

Board layout becomes more critical at higher current levels. Running too much current through a narrow trace can turn the trace into a fuse. Even with a wide trace, the resistance presented can cause problems. For 1 oz. copper, a 0.10 inch wide trace that is 0.7 inches long can easily handle up

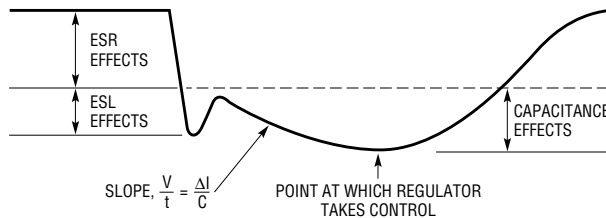

Figure 1. Transient effects

to 10A of current. However, the same trace has a resistance of 3mΩ. This adds 30mV to the overall dropout voltage of the regulator, and without remote load sensing, adds a 30mV load regulation error to the output. Remote load sensing can virtually eliminate the problems associated with the parasitic trace resistance, but cannot remove the added dropout voltage. Adding 30mV to the dropout voltage constitutes an increase of 7%. This additional drop reduces the available headroom, and can reduce the maximum available output current. Additional consideration must be given to power dissipation in the copper trace. With 10A of current and 30mV of drop across the trace, 0.3W of power is being dissipated in the trace alone. This can add to the overall problem of system-level thermal management. It is recommended that a good reference source be consulted to determine minimum required trace widths.¹

High frequency current transients also necessitate careful attention to board layout. Load current steps contain higher order frequency components that must be handled by the output decoupling network until the regulator throttles to the new load current level. Capacitors are not ideal elements and contain parasitic resistance and inductance that dominate the change in output voltage at the beginning of a load transient step. Using capacitors with low ESR, low ESL and good high frequency characteristics is critical in high speed applications. The location of the decoupling network is critical to transient performance.

For DC operation, the designer's main concern will be parasitic resistance. Consideration must be given to all high current paths to minimize the parasitic resistance and inductance present in the input, output and ground paths for the regulator. Maximize the trace widths for all high

currents paths in the layout. The best solution requires a multilayer board. With one layer devoted to power and a separate layer for the return path, narrow copper traces are replaced with entire copper planes. With power and ground planes, parasitic resistance is reduced to nearly zero. An additional benefit is the elimination of the power dissipation in copper traces, easing system-level thermal management.

When considering the transient performance, higher order frequency components must not be neglected. Capacitors with low ESR and low ESL are a necessity. Transient load currents through the ESR of a capacitor shows up as an instantaneous droop in output voltage ($\Delta V = \Delta I \cdot ESR$). When load current steps occur, parasitic inductance tries to limit the rate of change of the current. The result is a voltage spike at the start of the load transient. This spike is defined by $V = L \cdot di/dt$, where L is the ESL of the capacitors and their interconnecting traces. These transient effects are illustrated in Figure 1. Decoupling capacitors should be placed as close to the load as possible, with multiple capacitors used to distribute and reduce overall parasitics. Any narrow traces will increase parasitic inductance. Using power planes can reduce these effects, but will not eliminate them entirely. Other possible problems can occur when using vias to connect capacitors to inner plane layers, as they have parasitic inductance and resistance as well. The use of multiple vias is highly recommended to reduce parasitics. Also, be sure to minimize the distance between pads and vias.

Thermal Management for the LT1581

Even at the minimum differential voltages, power dissipation in the LT1581 can reach several watts. Without adequate heat sinking, maximum rated junction temperature can easily be exceeded. Excessive junction temperature will reduce the reliability of the part. By using an adequate heat sink, junction temperature can

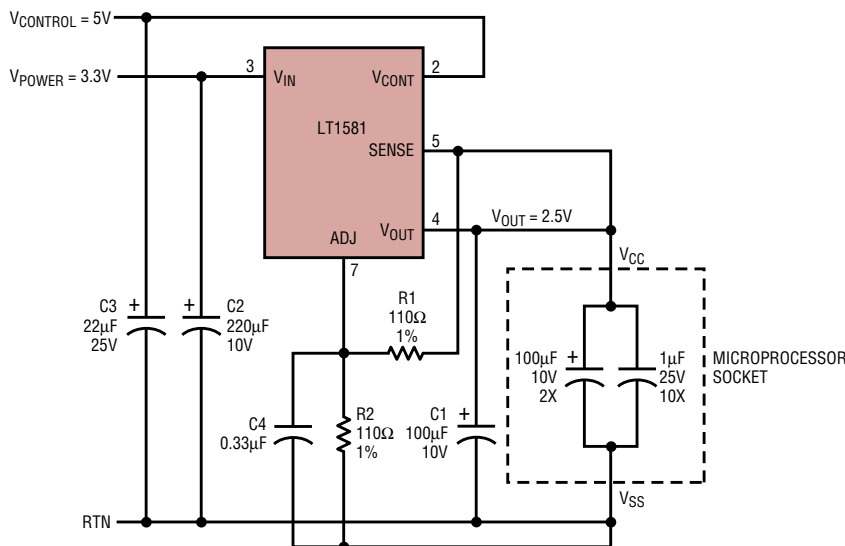

Figure 2. The LT1581 delivers 2.5V from 3.3V at up to 9A.

be maintained well under maximum, ensuring reliable operation.

Power dissipation is made up of two main components: the power in the output transistor and the power in the drive circuit. The power in the additional control circuitry is negligible at a maximum of 25mW.

To calculate the total power dissipation, use the following formula:

$$P_{TOTAL} = P_{OUTPUT} + P_{DRIVE}$$

where $P_{OUTPUT} = (V_{POWER} - V_{OUT})(I_{OUT})$
and $P_{DRIVE} = (V_{CONTROL} - V_{OUT})(I_{CONTROL})$

$I_{CONTROL}$ is a function of output current and is equal to between $I_{OUT}/150$ (typ) and $I_{OUT}/58$ (max).

The electrical characteristics section of the LT1581 data sheet provides separate thermal resistances and maximum junction temperatures for both the control circuitry and the power transistor. These specifications have been developed to more accurately reflect device temperature and ensure safe operating temperatures. Maximum junction temperature must be calculated for both sections to ensure that both thermal limits are met.

Junction-to-case thermal resistance is specified from the IC junction to the bottom of the case directly below the die. This is the lowest resistance path for heat flow. Proper mounting is required to ensure the best possible thermal flow from this area of the package to the heat sink. Please consult Linear Technology's "Mounting Considerations for Power Semiconductors," 1990 *Linear Applications Handbook*, Volume 1, pages

RR3-1 to RR3-20. Note that the case of the LT1581 is electrically connected to the output.

The following example illustrates how to calculate the heat sink size needed to ensure reliable operation of the LT1581. The circuit in Figure 2 is used with the following assumptions:

$$V_{CONTROL} \text{ (max continuous)} = 5.25V \text{ (} 5V + 5\% \text{),}$$

$$V_{POWER} \text{ (max continuous)} = 3.465V \text{ (} 3.3V + 5\% \text{),}$$

$$V_{OUT} = 2.5V, I_{OUT} = 8A, T_A = 40^\circ C,$$

$$\theta_{CASE-HEAT SINK} = 1^\circ C/W \text{ (with thermal compound).}$$

The following specifications are from the LT1581 data sheet:

$$R_{\theta_{JC}(CONTROL)} = 0.65^\circ C/W,$$

$$R_{\theta_{JC}(POWER)} = 2.5^\circ C/W,$$

$$T_{J(MAX)} = 125^\circ C \text{ for the control section, } 150^\circ C \text{ for the power section.}$$

Power dissipation under these conditions is equal to:

$$P_{DRIVE} = (V_{CONTROL} - V_{OUT})(I_{CONTROL})$$

$$I_{CONTROL} = I_{OUT}/58 = 8A/58 = 138mA$$

$$P_{DRIVE} = (5.25V - 2.5V)(138mA) = 380mW$$

$$P_{OUTPUT} = (V_{POWER} - V_{OUT})(I_{OUT})$$

$$= (3.465V - 2.5V)(8A) = 7.72W$$

$$\text{Total Power Dissipation} = 8.1W$$

Junction temperature will be equal to:

$$T_J = T_A + P_{TOTAL} (\theta_{HEAT SINK} + \theta_{CASE-HEAT SINK} + \theta_{JC})$$

For the control section:

$$T_{J(MAX)} = 125^\circ C = 40^\circ C + 8.1W(\theta_{HEAT SINK} + 1^\circ C/W + 0.65^\circ C/W)$$

$$\theta_{HEAT SINK} + 1.65^\circ C/W = (125^\circ C - 40^\circ C)/8.1W$$

$$\theta_{HEAT SINK(MAX)} = 8.8^\circ C/W$$

For the power section:

$$T_{J(MAX)} = 150^\circ C = 40^\circ C + 8.1W(\theta_{HEAT SINK} + 1^\circ C/W + 2.5^\circ C/W)$$

$$\theta_{HEAT SINK} + 3.5^\circ C/W = (150^\circ C - 40^\circ C)/8.1W$$

$$\theta_{HEAT SINK(MAX)} = 10^\circ C/W$$

As shown, the maximum thermal resistance for the heat sink must be below $8.8^\circ C/W$ to ensure reliable operation from the LT1581. This resistance value can be used to specify the heat sink and airflow requirements needed to operate the LT1581 below specified thermal limits.

Conclusion

The LT1581 can be used for a variety of applications where high current and low dropout voltage are a must. It can deliver up to 10A of output current at a typical dropout voltage of 430mV. A remote-sense pin virtually eliminates load regulation problems. Supply-sequencing issues have been eliminated. The LT1581's excellent transient performance makes it suitable for high current applications where load current transients occur at high frequency. The low dropout voltage reduces the amount of input/output differential voltage required and simultaneously reduces the power dissipation in the regulator. When consideration is given to board layout and thermal management, performance can be maximized. 

¹Fink, D.G. and D. Christiansen: *Electronic Engineers' Handbook* (Second Edition). McGraw Hill, 1982. Figure 7-75.



The LT1370: New 500kHz, 6A Monolithic Boost Converter

by Karl Edwards

Introduction

Complementing and expanding on the current LT1371/LT1372 family of 500kHz switchers, Linear Technology introduces the LT1370, a 6A boost converter. At 65mΩ on-resistance, 42V maximum switch voltage and 500kHz switching frequency, the LT1370 can be used in a wide range of output voltage and current applications.

The high efficiency switch is included on the die, along with the oscillator, control and protection circuitry necessary for a complete switching regulator. This part combines the convenience and low parts count of a monolithic solution with the switching capabilities of a discrete power device and controller. All the features found on the LT1371/LT1372 have been retained on the LT1370, including current mode operation, external synchronization and low current shutdown mode (12μA typical). Only a few surface mount components are needed to complete a small, high efficiency DC/DC converter. The LT1370 will operate in all the standard switching configurations, including boost, buck, flyback, forward, inverting and SEPIC.

LT1370 Features

- ❑ 6A Minimum switch-current limit
- ❑ Constant 500kHz switching frequency
- ❑ 65mΩ high speed switch
- ❑ 12μA shutdown current
- ❑ 2.7V minimum input operating voltage
- ❑ Cycle-by-cycle current limiting
- ❑ Available in DD and TO-220 packages
- ❑ 42V switch voltage

Circuit Description

The LT1370 is a current mode switcher. This means that switch duty cycle is directly controlled by the switch current rather than by the output voltage. Referring to Figure 1, the switch is turned on at the start of each oscillator cycle. It is turned off when the switch current reaches a predetermined level. The switch-off current threshold is controlled by an output voltage error amplifier. This technique has several advantages. First, it responds quickly to input voltage variations, unlike voltage mode switchers, which have notoriously poor line-transient response. Second, it reduces the 90° phase shift at mid-frequencies in the energy storage inductor. This greatly simplifies closed-loop frequency compensation under widely varying input voltage and output load conditions. Finally, it allows simple pulse-by-pulse current limiting to provide maximum switch protection under output overload or short-circuit conditions. A low dropout internal regulator provides a 2.3V supply to all internal circuitry.

This low dropout design allows the input voltage to vary from 2.7V to 25V with virtually no change in device performance. An internal 500kHz oscillator is the basic clock for all timing. It turns the output on via logic and driver circuitry. Special adaptive antisaturation circuitry detects the onset of saturation in the power switch and adjusts driver current instantaneously to limit switch saturation. This minimizes driver dissipation and provides very rapid turn off of the switch.

A 1.245V bandgap reference biases the positive input of the error amplifier. The negative input of the amplifier is brought out for positive output voltage sensing. The error amplifier has nonlinear transconductance to reduce output overshoot on start-up or overload recovery. When the feedback voltage exceeds the reference by 40mV, error amplifier transconductance increases by a factor of ten. This allows the current-trip threshold, set by V_C , to be lowered faster, reducing overshoot. The feedback input also

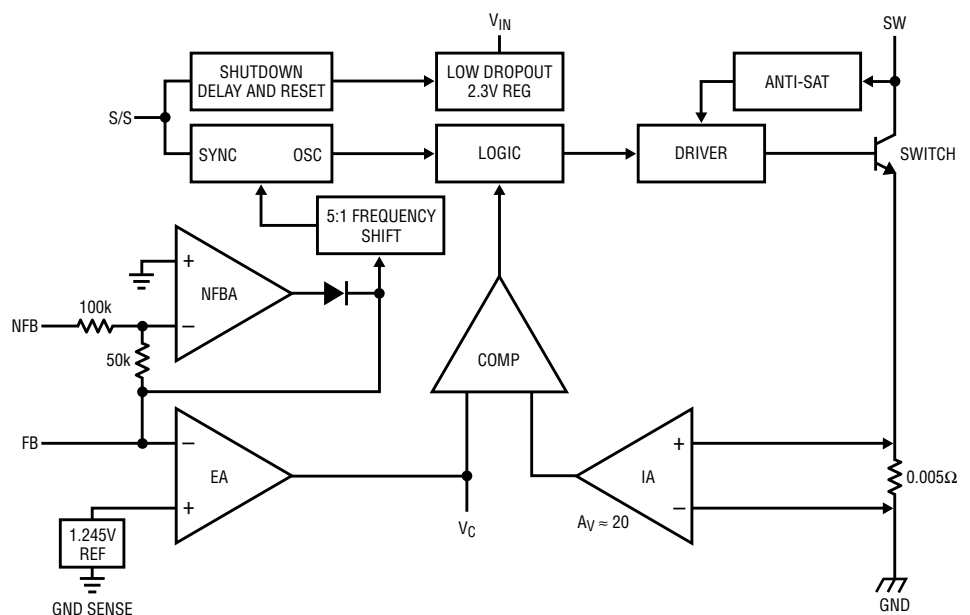

Figure 1. LT1370 block diagram

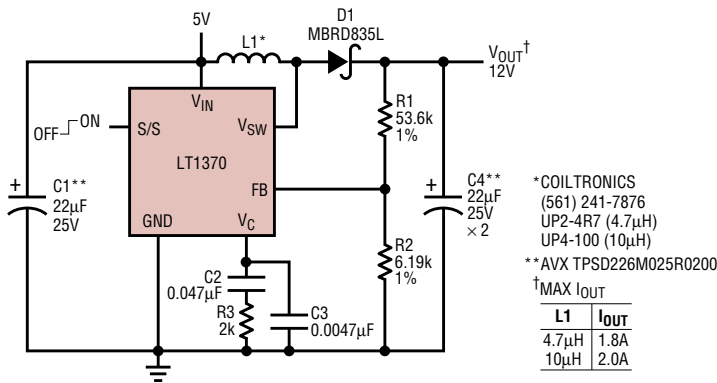

Figure 2. 5V to 12V boost converter

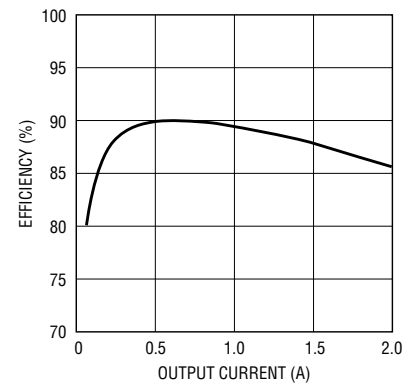

Figure 3. 12V output efficiency

invokes oscillator frequency shifting, which helps protect components during overload conditions. When the feedback voltage drops below 0.6V, the oscillator frequency is reduced 5:1, to 100kHz. Lower switching frequency, with the same minimum on time, reduces the minimum switch duty cycle and short-circuit current in the inductor.

Similar to the LT1371, error amplifier circuitry allows the LT1370 to directly regulate negative output voltages. The NFB pin regulates at -2.49V while the amplifier's output internally drives the FB pin to 1.245V. This architecture, which uses the same main error amplifier, avoids duplication of functions and maintains ease of use. The error signal developed at the amplifier output is brought out externally to the V_C pin. The V_C pin has three different functions. It is used for frequency compensation, current limit adjustment and soft starting. During normal regulator operation, this pin is in the voltage range of 1V to 1.9V. The error amplifier is a current output (g_m) type, so this voltage can be externally clamped to lower the current limit. Likewise, a capacitor-coupled external clamp provides soft start. Switch duty cycle goes to zero if the V_C pin is pulled below the control threshold (typically 1V), placing the LT1370 in an idle mode.

The S/S pin has two functions, synchronization and shutdown. The internal oscillator can be synchronized to a higher frequency by applying a TTL square wave to this pin. This allows the part to be synchronized to

a system clock. If the S/S pin is held low, after a short delay the LT1370 will enter shutdown mode. In shutdown mode, all internal circuitry is disabled, reducing supply current to 12µA. An internal pull-up ensures start-up when the S/S pin is left open.

5V to 12V Boost Converter

Figure 2 shows a typical 5V to 12V boost application. The feedback divider network has been selected to give the desired output voltage. As long as R2 is less than 7k, FB input bias current can be ignored. The inductor needs to be chosen carefully to meet both peak and average current values. The output capacitor can see high ripple currents—often, as in this application, higher than the ripple rating of a single capacitor. This requires the use of two surface mount tantalums in parallel; both capacitors should be of the same value and manufacturer. The input capacitor does not have to endure such high ripple currents and a single capacitor will normally suffice. The catch diode, D1, must be rated for the output voltage and average output current. The compensation capacitor, C2, normally forms a pole in the 2Hz to 20Hz range, with a series resistor, R3, to add a zero at 1kHz to 5kHz.

A second capacitor, C3, is sometimes required to prevent erratic switching. Ripple current in the output capacitor's ESR causes voltage ripple. This feeds back through the error amp to the V_C pin, changing the current-trip threshold cycle-to-cycle. The problem appears as subharmonic

oscillation. Adding C3, typically one-tenth the value of the main compensation capacitor, reduces the loop gain at the switching frequency, preventing the oscillation.

The ground return from the compensation network must be separate from the high current switch ground. If drops in the ground trace due to switch current cause the V_C pin to dip, premature switch-off will occur. This effect appears as poor load regulation. A solution to this is to return the compensation network to the FB pin. The S/S pin in this example is driven by a logical on/off signal, a low input forcing the LT1370 into its 12µA shutdown mode. Figure 3 shows the overall converter efficiency. Note that peak efficiency is over 90%; efficiency stays above 86% at the device's maximum operating current.

Positive-to-Negative Converter

The NFB (negative feedback) pin allows negative output regulators to be designed with direct feedback. In the circuit shown in Figure 4, a 2.7V to 13V input, -5V output converter, the output is monitored by the NFB pin and a simple divider network. No complex level shifting or unusual grounding techniques are required. The regular FB pin is left open circuit and the divider network, R2, R3, is calculated based on the -2.49V NFB reference voltage and 30µA of input current. The switch-clamp diodes, D2 and D3, prevent the leakage spike from the transformer, T1, from

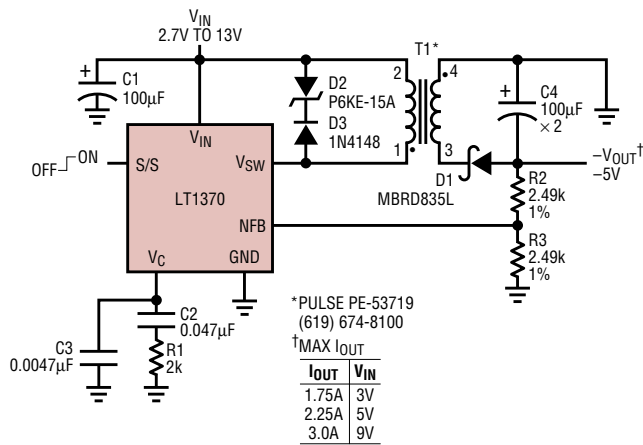



Figure 4. Positive-to-negative converter with direct feedback

rent range. With good layout, the DD package can have a thermal resistance as low as 20°C/W to 30°C/W, junction-to-ambient. In the boost converter shown in Figure 2, with an input voltage of 5V and an output voltage of 12V at 2A, power dissipation in the LT1370 is 2.2W. This causes a 50°C to 60°C rise in die temperature above ambient. Maximum junction temperature is 125°C, so this application would be able to operate up to a 70°C ambient.

Conclusion

With its low resistance switch, 6A operating current and 500kHz operation, the LT1370 is ideal for small, low parts count, high current applications. Its high switching frequency eliminates the need for bulky magnetics and capacitors. Compared to a separate control device and power switch, the LT1370's monolithic approach simplifies the design effort required to implement a complete DC/DC converter. The choice of TO-220 and surface mount DD package, 42V switch, and flexibility of switching topologies makes the LT1370 ideal for a wide range of applications. The LT1370 extends Linear Technology's LT1371 and LT1372 family of 500kHz, monolithic switchers all the way up to 6A. 

exceeding the switch's absolute maximum voltage rating. The Zener voltage of D2 must be higher than the output voltage, but low enough that the sum of input voltage and clamp voltage does not exceed the switch voltage rating.

5V SEPIC Converter

Figure 5 shows a SEPIC converter. One of the advantages of the SEPIC topology is that the input voltage can range from below to above the output voltage. In Figure 5, the input voltage range is from 4V to 9V, with a 5V output. The magnetic coupling of inductors L1A and L1B is not critical for operation, but generally they are wound on the same core. C2 couples

the inductors together and eliminates the need for a switch snubber network. C2 must have a very low ESR, because the ripple current is equal to $I_{SW}/2$. Its capacitance value is not critical and has no significant effect on loop stability. The voltage across C2 is equal to the input. A 4.7µF, 50V ceramic will work in most SEPIC applications. The S/S pin is used as a logical on/off signal. In the off state, there is no leakage to the output, and only 12µA leakage from the input.

Thermal Performance

Due to the very low on-resistance of the LT1370 switch and its driver efficiency, the surface mount DD package version can be used over its full cur-

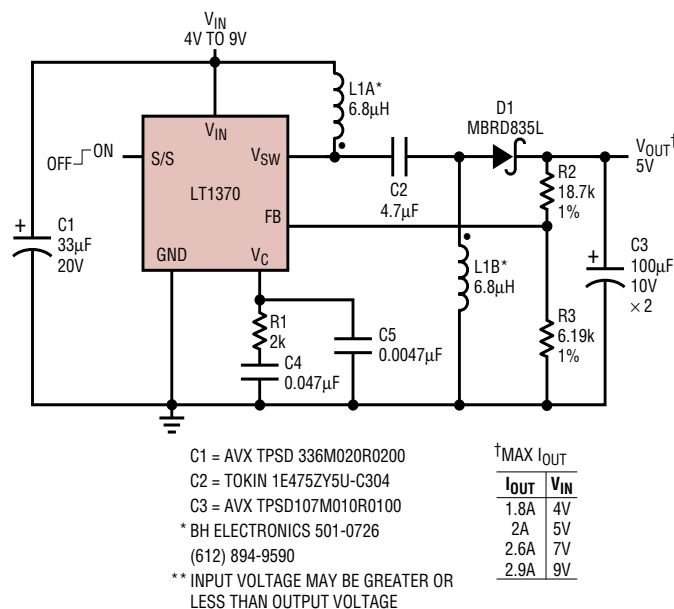

Figure 5. Two Li-Ion cells to 5V SEPIC converter

New LTC1504: Flexible, Efficient Synchronous Switching Regulator Can Source or Sink 500mA

by Dave Dwelley

Introduction

The LTC1504 is a new addition to LTC's family of 8-pin step-down switching regulators. It consists of a 200kHz fixed frequency, voltage-feedback, buck-mode switching regulator controller and a pair of 1.5Ω power switches in an 8-pin SO package. The LTC1504 also includes a synchronous rectifier on-chip, maximizing efficiency and minimizing external parts count while allowing the output to both sink and source current: it can source or sink up to 500mA with input voltages from 3.3V to 10V and output voltages as low as 1.26V. The LTC1504 can achieve 100% duty cycle at the output switch, maximizing dropout performance with low input-to-output voltage differentials. The LTC1504 includes an onboard precision reference and user-programmable current-limit and soft-start circuits, allowing implementation of full-featured power conversion circuits with a minimum of external components. The architecture is optimized for maximum efficiency at loads above 50mA and

does not include a light-load Burst Mode™ circuit. This penalizes efficiency at very light loads but allows the device to seamlessly shift between sourcing and sinking current, opening up a whole new class of applications. A micropower shutdown mode is included. The diminutive SO-8 package minimizes the amount of space the LTC1504 fills while allowing adequate thermal dissipation for 500mA load current levels. The LTC1504 allows previously impossible (or at least awkward) tasks to be completed with ease.

Minimum Component-Count Circuits

Figure 1 shows a fully functional LTC1504 5V to 3.3V regulator, including current limit and soft-start, using the fixed-output LTC1504-3.3 and only six external components. The on-chip synchronous rectifier eliminates the need for an external catch diode, and the internal current-limit circuit requires only a single resistor to program the maximum

output current. Efficiency is above 90% with load currents between 50mA and 200mA, peaking at 92% at 100mA and remaining above 82% all the way to the maximum 500mA load. Current limit is set at 500mA in this example; it can be reduced by lowering the value of R_{IMAX}. C_{SS} sets the start-up time at approximately 25ms. Both the current limit resistor (R_{IMAX}) and soft-start capacitor (C_{SS}) are optional; either can be deleted and its pin left floating if the functionality is not needed. An LTC1504 circuit can be constructed with just four components: input and output capacitors, an external inductor and a compensation capacitor.

The circuit in Figure 1 relies on the ESR of the output capacitor to maintain loop stability with just a single capacitor at the COMP pin. Figure 1 uses a surface mount electrolytic capacitor with about 400mΩ ESR. A low ESR tantalum output capacitor can improve the transient response at the output but requires a more complex compensation network at the

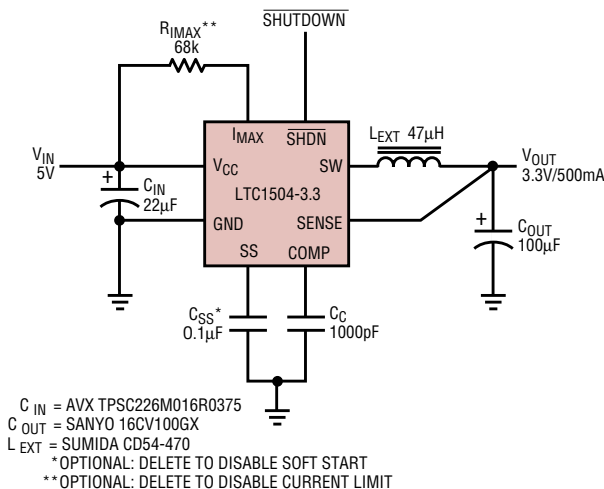

Figure 1. Minimum parts count 5V-3.3V converter

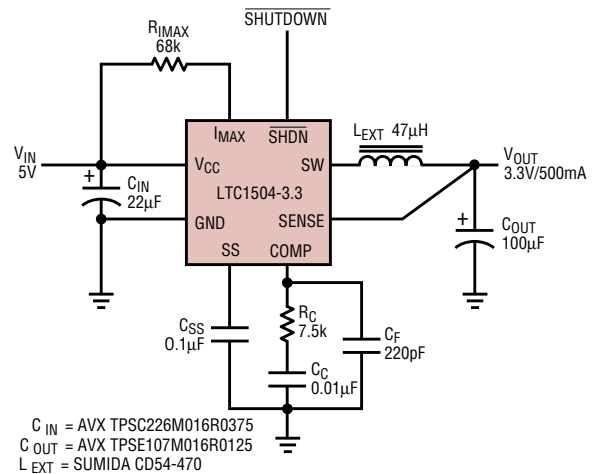

Figure 2. Improved transient response

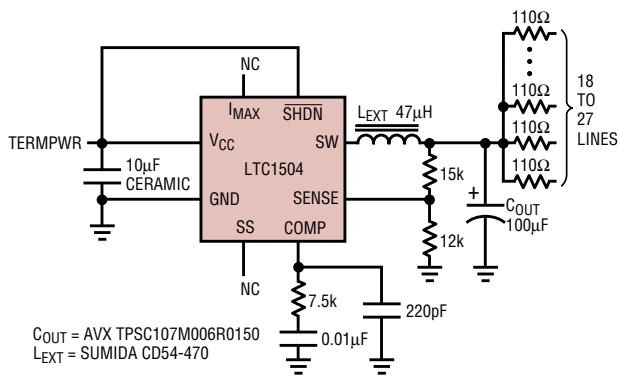

Figure 3. SCSII-2 active terminator

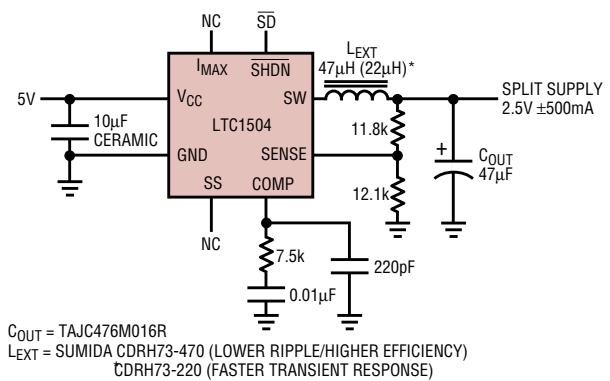

Figure 4. 5V supply splitter

COMP pin (Figure 2). There is a tradeoff to be made here: the minimum component count solution is the simplest and uses the least expensive components but pays a penalty in transient response. The low ESR circuit in Figure 2 has improved transient response and actually uses less board space: the tantalum output capacitor is smaller than the electrolytic device used in Figure 1 and the additional compensation components are tiny 0603 surface mount devices. Unfortunately, the tantalum capacitor used in Figure 2 costs significantly more than the electrolytic device in Figure 1. You don't get something for nothing.

Note that the input bypass capacitor in both Figures 1 and 2 is an AVX TPS type, a relatively costly surge-tested tantalum capacitor. This is a small, surface mount device that has a surge current rating adequate to support the 500mA maximum load current of the LTC1504. Buck regulators (like the LTC1504) inherently draw large RMS currents from the input bypass capacitor, and the capacitor type chosen must be capable of withstanding this current without overheating. Different input bypass capacitors can be used *if* their ripple current rating is sufficient to withstand the expected demand (as a rule of thumb, one-half the maximum expected output current). Just as you wouldn't specify a 1/4W resistor to dissipate 1W of power, neither should you specify an inadequate input bypass capacitor for a buck regulator.

Tiny, expensive 10µF ceramic capacitors work well, as do larger, cheaper electrolytic capacitors with specified ripple-current ratings. Circuits using electrolytic input bypass devices often require an additional 0.1µF ceramic capacitor right next to the LTC1504 to keep the input capacitor ESR under control. As with all switching regulator circuits, layout is critical to obtaining maximum performance; if in doubt, contact the LTC Applications Department for component selection and layout advice.

Sink/Source Capability Improves SCSI Terminators and Supply Splitters

Figure 3 shows an adjustable-output LTC1504 connected as a 2.85V regulator for use as a SCSI terminator. The ability of the LTC1504 circuit to sink current makes it ideal for use in terminator applications, where the load is just as likely to be putting current into the regulator as taking it out. The synchronous-buck architecture of the LTC1504 allows it to shift cleanly between sourcing and sinking current, making it ideal for such applications. The high efficiency minimizes the power drawn from the TERMPWR supply and minimizes the heat generated by the terminator circuit. Finally, the small number of tiny external components required minimizes the space used by the terminator circuit. As in Figure 2, a low ESR output capacitor is used along with an optimized compensation network to improve output transient

response and maintain maximum data fidelity.

Substituting a different set of feedback resistors (Figure 4) creates a 5V supply splitter, which creates a 2.5V "ground" to allow analog circuitry to operate from split supplies. Op amp circuits and data converters like to operate from dual supplies, and the sink/source capability of the LTC1504 allows load currents to be returned directly to the 2.5V "ground" supply. The fast transient response of the LTC1504 keeps the generated "ground" voltage clean even as the load switches rapidly between sinking and sourcing current. Additionally, the circuit in Figure 4 is significantly more efficient than the traditional resistor-divider method of supply splitting at higher power levels.

Conclusion

The LTC1504 brings the benefits of synchronous rectification to LTC's family of 8-pin switching regulators. It provides a full-featured, high efficiency, 500mA supply in a minimum-size, minimum-parts-count implementation. The LTC1504 is a natural fit in terminator circuits, supply-splitters and other applications that require the output to both source and sink current. Other uses include distributed power, microprocessor secondary-voltage supplies, low voltage, battery powered devices and anywhere else a high efficiency, low parts count, 500mA step-down supply is required. 

Low Dropout Regulator Driver Handles Fast Load Transients and Operates on Single 3V–10V Input

by Lenny Hsiu

Introduction

The LT1573 is the latest low dropout voltage regulator driver from Linear Technology. The LT1573 is designed to provide a low cost solution to applications requiring high current, low dropout and fast transient response. When combined with an external PNP power transistor, this device provides up to 5A of load current with dropout voltages as low as 0.35V. The LT1573's circuitry is designed for extremely fast transient response. This greatly reduces the bulk storage capacitance required when the regulator is used in applications with fast, high current load transients.

To keep cost and complexity low, the LT1573 uses a new, time-delayed latching current protection technique that requires no external current sense resistor. Base-drive current to the external PNP is limited for instantaneous protection and a time-delayed latch protects the regulator from continuous short circuits. The latch time-out period can be varied by an external capacitor. Guaranteed minimum available base-drive current to the external PNP is 250mA. An exter-

nal resistor can be added to reduce the available base-drive current and thereby limit the regulator output current. The LT1573 is equipped with an active-high shutdown and a thermal shutdown function. The shutdown function can be used to reset the overcurrent latch. The thermal shutdown function can be used to protect the PNP power transistor if it is thermally coupled to the LT1573.

The LT1573 is available as an adjustable regulator with an output range of 1.27V to 6.8V and with fixed output voltages of 2.5V, 2.8V and 3.3V. Output accuracy is better than 1% to meet the critical regulation requirement of fast microprocessors. A special 8-pin fused-lead surface mount package is used to minimize regulator footprint and provide adequate heat sinking.

Basic Regulator Circuit

The basic regulator circuit is shown in Figure 1. The adjustable-output LT1573 senses the regulator output voltage from its feedback pin via the output voltage divider and drives the base of the external PNP transistor to

maintain the regulator output at the specified value. For fixed-output versions of the LT1573, the regulator output voltage is sensed from the feedback pin via an internal voltage divider. The resistor R_D is required for the overcurrent latch-off function. R_D is also used to limit the drive current available to the external PNP transistor and to limit the power dissipation in the LT1573. Limiting the drive current to the external PNP transistor will limit the output current of the regulator, thereby minimizing the stress on the regulator circuit under overload conditions.

External PNP Transistor Selection Criteria

The selection of an appropriate external PNP transistor depends on the regulator application specifications. The critical PNP transistor selection criteria include:

1. The maximum output current of the PNP transistor
2. The dropout voltage at the maximum output current
3. The gain-bandwidth product, f_T , of the transistor

The PNP transistor must be able to supply the specified maximum regulator output current to be qualified for the regulator application. The V_{CE} saturation voltage of the transistor at the maximum output current determines the dropout voltage of the circuit. The dropout voltage determines the minimum regulator input voltage for a certain specified output voltage. The gain-bandwidth product, f_T , of the transistor determines how fast the voltage regulator can follow an output load change without losing voltage regulation.

The D45H11 from Motorola and the KSE45H11TU from Samsung can

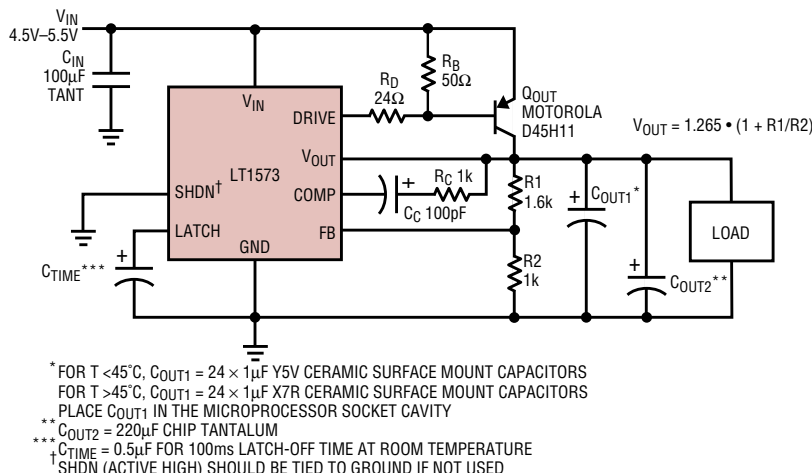

Figure 1. 3.3V, 5A microprocessor supply

Table 1. Dropout voltage of the D45H11

Drive Current	Output Current	Typical Dropout Voltage
20mA	1A	0.20V
20mA	2A	0.50V
40mA	2A	0.25V
40mA	3A	0.50V
60mA	3A	0.25V
60mA	4A	0.70V
80mA	4A	0.45V
100mA	4A	0.35V
100mA	5A	0.70V
150mA	5A	0.40V
200mA	5A	0.35V
150mA	6A	0.65V
200mA	6A	0.45V
250mA	7A	0.50V

be used in all LT1573 regulator circuits with current ratings up to 5A. The D45H11 can supply 5A of output current with dropout voltage as low as 0.35V. The gain-bandwidth product, f_T , of the D45H11 is typically 40MHz; this enables a regulator composed of this PNP transistor and an LT1573 to handle load changes of several amps in a few hundred nanoseconds with a minimum amount of output capacitance.

Dropout Voltage

The dropout voltage of an LT1573-based regulator circuit is determined by the V_{CE} saturation voltage of the discrete external PNP transistor when it is driven with a base current equal to the available drive current of the LT1573. The LT1573 is guaranteed to sink 250mA of base current (440mA typical). The available drive current of the LT1573 can be reduced by adding a resistor, R_D in Figure 1, in series with the drive pin. Table 1 lists some useful operating points for the D45H11 from Motorola. These points were empirically determined using a sample of devices.

Selecting R_D

Resistor R_D can be used to limit the available drive current to the external PNP transistor. In order to select R_D ,

the user should first choose the value of drive current that will give the required value of output current and dropout voltage. For circuits using a D45H11 as a pass transistor, this can be done using Table 1. For circuits using transistors other than the D45H11, the user must characterize the transistor to determine the drive-current requirements for the specified output current and dropout voltage. In general, it is recommended that the user choose the lowest value of drive current that will satisfy the output current requirements. This will minimize the stress on circuit components during overload conditions.

The value of R_D can be calculated with the following formula:

$$R_D = (V_{IN} - V_{BE} - V_{DRIVE}) / (I_{DRIVE} + I_{RB})$$

where:

V_{IN} = the minimum input voltage to the circuit

V_{BE} = the maximum emitter/base voltage of the PNP pass transistor

I_{DRIVE} = the minimum PNP base current required

I_{RB} = the current through R_B
 $= V_{BE} / R_B$

V_{DRIVE} = the Drive pin saturation voltage when the drive pin current equals $(I_{DRIVE} + I_{RB})$

Overcurrent Latch-Off

In addition to limiting the base-drive current, R_D is included in the circuit for the overcurrent protection latch-off function. There is a minimum value for this resistance. It is calculated by the formula above, with the drive current I_{DRIVE} set to the guaranteed minimum available drive current (= 250mA) from LT1573. Under some conditions, R_D can be replaced with a short. This is possible in circuits where an overload is unlikely and the input voltage and drive requirements are low. If R_D is not included in the circuit, the regulator is protected against overcurrent conditions only by the thermal-shutdown function. After the value of R_D is determined, a certain amount of base-drive current is available to the external PNP. An

overcurrent or output short-circuit condition will demand a base-drive current greater than the LT1573 can supply. The internal drive transistor will saturate. This overcurrent condition will trigger a time-out latch to turn off the regulator system. The time-out period is determined by an external capacitor connected between the LATCH and GND pins. The time-out period is equal to the time it takes for the capacitor to charge from 0V to the latch threshold. If the overcurrent or output short condition persists longer than the time-out period, the regulator will be shut down. Otherwise, the regulator will function normally. The latch can be reset by recycling input power, by grounding the latch pin or by putting the device into shutdown.

Shutdown Function

The regulator can be shut down and the overcurrent latch can be reset at the same time by pulling the SHDN pin voltage higher than the shutdown threshold (about 1.3V). The regulator will restart itself if the SHDN pin is pulled below the shutdown threshold. The shutdown pin voltage can be higher than the input voltage. When the shutdown pin voltage is higher than 2V, the shutdown pin current increases and is limited by a 20k resistor.

Compensation

Figure 1 shows a microprocessor power supply based on the LT1573 and the D45H11 PNP transistor, using twenty-four 1 μ F surface mount ceramic capacitors in parallel with one 220 μ F surface mount tantalum capacitor at the output. To improve the transient response to regulator output-load variation of this circuit, a capacitor in series with a resistor can be inserted between the OUTPUT and COMP pins; a 100pF capacitor in series with a 1k resistor is recommended. In theory, the output capacitor forms the a pole in the regulator system. An internal compensation capacitor forms another pole. The external compensation ca-

continued on page 24

LT1579 Battery-Backup Regulator Provides Uninterruptible Power

by Todd Owen

Introduction

Many products, such as critical data acquisition systems and process controllers, need to operate continuously even when primary power is interrupted. Primary power for these systems may come from a wall adapter, a battery-charging unit powered from the line or a removable battery. For a line-powered circuit, a backup battery may provide reserve power until line power is restored. In the case of a battery-charging unit, the battery automatically provides power during a line outage. With removable batteries, a secondary backup battery is needed to maintain power when the main battery is discharged or removed.

These circuits have several common requirements, regardless of the power source. Most important is the need for the regulated voltage to be provided to critical circuitry at all times. The switch from one input source to another should be seamless, without significant change in the output. The input source that provides power to the circuit first can also be important (for example, the main battery should provide power before the backup battery, regardless of which has the higher terminal voltage). Additionally, some form of power monitoring circuitry may be needed to help in power management.

Smart Regulator Makes the Grade

Designed for a multitude of applications, the LT1579 is a dual input, single output, low dropout regulator that provides an uninterruptible output voltage from two independent input voltage sources on a priority basis. All power supplied to the load is drawn from the primary input (V_{IN1}) until the device senses that the primary source is failing. At this point, the LT1579 smoothly switches from the primary input to the secondary input (V_{IN2}) to maintain output regu-

lation. The LT1579 is capable of providing 300mA from either input at a dropout voltage of 0.4V. Total quiescent current is 50 μ A: 45 μ A from the primary input source, 2 μ A from the secondary input source, and an additional 3 μ A from the higher voltage of the two.

A block diagram of the LT1579 is shown in Figure 1. A single error amplifier controls both output stages so regulation remains tight regardless of which input is providing power. Threshold levels for the error amplifier and low-battery detectors are set by the internal 1.5V reference. Output voltage is set by an internal resistor divider for fixed voltage parts and by an external divider for adjustable parts. Internal bias circuitry powers the reference, error amplifier,

output driver controls, logic flags and low-battery comparators.

The LT1579 is designed to maintain regulation even if one of the inputs is instantaneously removed. If the primary input is supplying load current, removal and insertion of the secondary input creates no noticeable transient at the output. In this case, the LT1579 continues to supply current from the primary; no switching is required. If the primary input source is unplugged while it is supplying load current, the LT1579 must quickly switch to the secondary source. In this case, the LT1579 sees the input capacitor as a rapidly discharging battery. If it discharges too quickly, the LT1579 does not have sufficient time to switch over without a large transient occurring at the

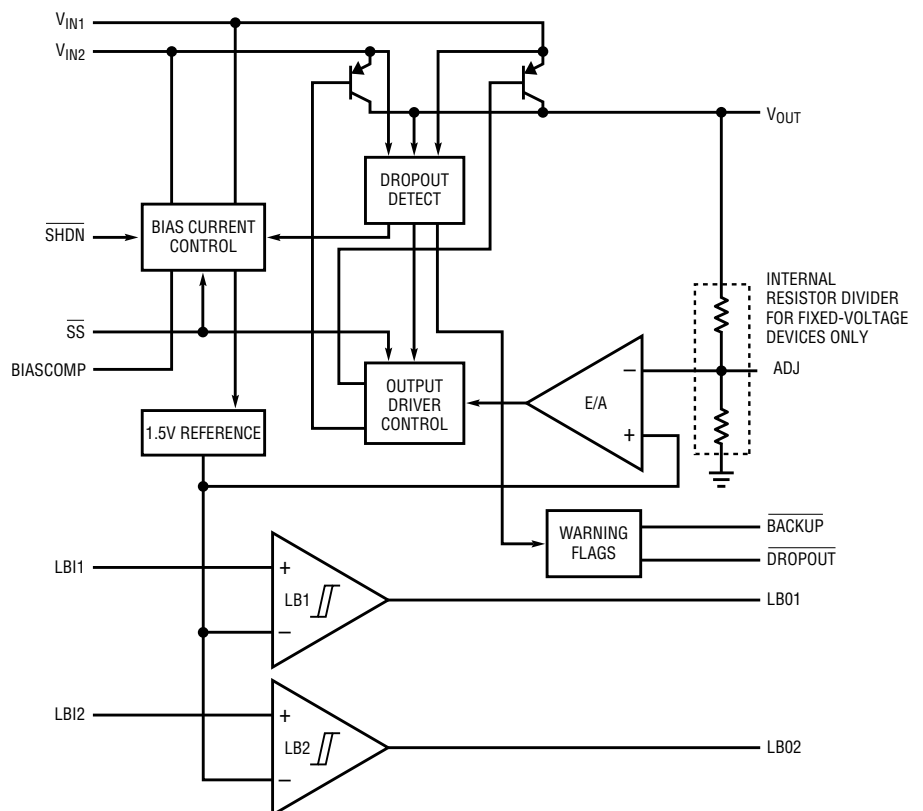

Figure 1. LT1579 block diagram

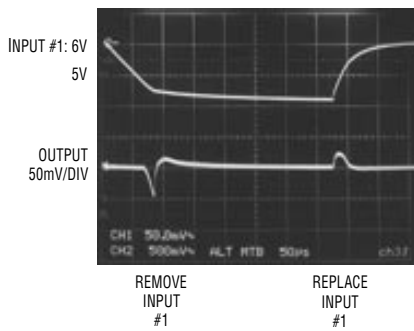

Figure 2. Output deviation during removal and replacement of primary input source

output. The input capacitor must be large enough to supply load current during the transition from primary to secondary input. Plugging the primary input back in creates a smaller transient on the output because both inputs are present to supply current during the transition. Figure 2 shows a typical output transient using 10 μ F input and output capacitors and a 100mA load. Peak output deviation is less than 50mV. Proportionally larger values for input and output capacitors are needed to limit peak deviations on the output when delivering larger load currents.

The LT1579 incorporates two independent low-battery comparators and two status flags that provide information to power management circuitry. The status flags show which input is supplying power to the load and provide an early warning against the loss of output regulation. A Secondary Select pin can be used to force the switchover from the primary input to the secondary. This active low logic pin reduces power draw from the primary input to only 2 μ A. This provides excellent protection for batteries that are sensitive to deep-discharge conditions, such as Li-Ion cells. The part can be put into a low power shutdown state where all bias currents and device functions are turned off and all logic flags are high impedance. In shutdown, the quiescent current drops to a total of only 7 μ A: 2 μ A from the primary input, 2 μ A from the secondary input and 3 μ A from the higher of the two input voltages.

Internal protection circuitry in the LT1579 guards against a number of fault conditions. Protection circuitry

includes thermal-overload protection, reverse-battery protection, input-to-input current protection, reverse-current protection and overcurrent protection. If maximum junction temperature is exceeded, the LT1579 will shut off to prevent internal damage. If either input is reversed, reverse current flow will be limited to less than 1mA. Inputs are isolated from one another. No current will flow between inputs, regardless of their relative voltages. If the output is held high while the inputs are grounded, reverse currents are limited to 7 μ A. Current-limit protection is designed to protect the device if the output is shorted to ground. With the output shorted to ground, current will be drawn from the primary input until it is discharged. No current is drawn from the secondary input until the primary input is discharged.

Circuit Examples

The basic application of the LT1579 is shown in Figure 3. It uses two independent voltage sources for the inputs. These voltage sources may be batteries, wall adapters or any other DC source. The low-battery comparators are configured to give a low output if either input voltage drops below 5.5V. The trip points can be adjusted by changing the values of the divider resistors (R1 and R2 for LB1, R3 and R4 for LB2). All logic outputs (LBO1, LBO2, BACKUP and DROPOUT) are open-collector outputs that require an external pull-up resistor. They are capable of sinking 20 μ A at a maximum output voltage of 0.32V, which is useful for driving both CMOS and TTL logic families. For driving LED's,

all logic outputs can sink 5mA at a maximum output voltage of 1.2V.

Figure 4 is the timing diagram for the basic circuit. No time scale is shown for the timing diagram because actual discharge rates are a function of the load current and the type of batteries used. The timing diagram is meant as a tool to help in understanding the LT1579's basic operation.

Five milestones are noted on the timing diagram. Time A is where the primary input voltage drops enough to trip the low-battery detector, LB1.

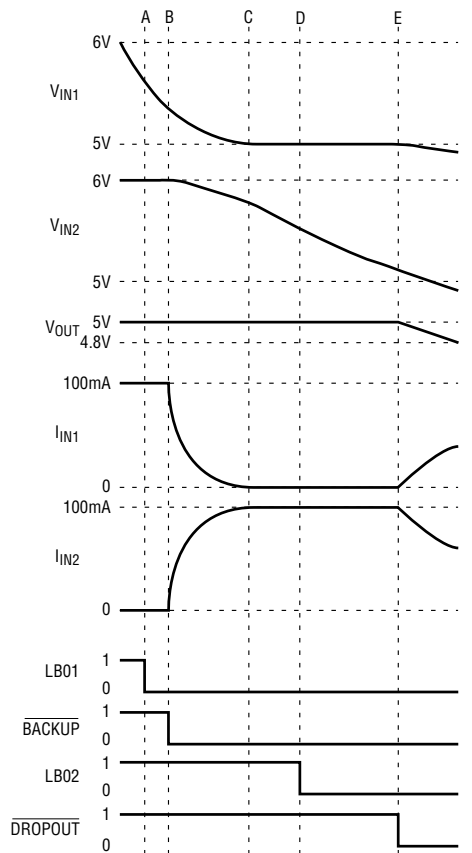

Figure 4. Basic application timing diagram

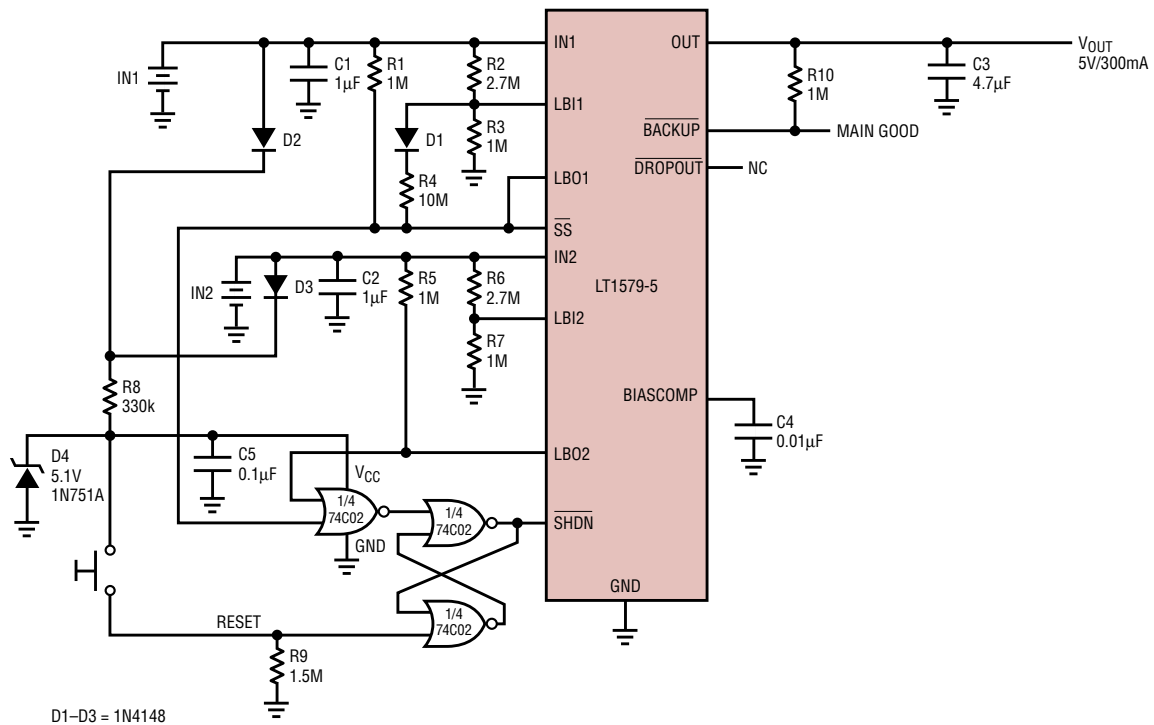

Figure 5. Added SR latch shuts the LT1579 off when both low-battery detectors are tripped.

The trip threshold for LB1 is set at 5.5V, slightly above the dropout voltage of the primary input. At time B, the $\overline{\text{BACKUP}}$ flag goes low, signaling the beginning of the transition from the primary source to the secondary source. Between times B and C, the input current makes a smooth transition from V_{IN1} to V_{IN2} . By time C, the primary battery has exhausted most of its useful charge. The primary input will still deliver a small amount of current to the load, diminishing as the primary input voltage drops. By time D, the secondary battery has dropped to a low enough voltage to trip the second low-battery detector, LB2. The trip threshold for LB2 is also set at 5.5V, slightly above where the secondary input reaches dropout. At time E, both inputs are low enough to cause the LT1579 to enter dropout, with the $\overline{\text{DROPOUT}}$ flag signaling the impending loss of output regulation.

Some interesting things can be noted on the timing diagram. The amount of current available from a given input is determined by the input/output voltage differential. As the primary voltage drops, the amount of current drawn from the input also drops, slowing discharge of the bat-

tery. Dropout-detection circuitry will maintain the maximum current draw from the input for the given input/output voltage differential, based on the impedance of the pass transistor. In the case shown, this causes the current drawn from the primary to approach zero, although it never reaches that point. Note that the primary begins to supply significant current again when the secondary input drops low enough to cause a loss in output regulation. This occurs because the input/output voltage differential of the primary input increases as the output voltage drops. The LT1579 will automatically maximize the power drawn from the inputs to maintain the highest possible output voltage.

A final circuit example is shown in Figure 5. This circuit has a few notable changes from the basic application. First, the Secondary Select pin is connected directly to LBO1. When the primary input voltage drops below the threshold level for LB1, the comparator output will pull the Secondary Select pin low. This forces the device to switch completely over to the secondary input, limiting the discharge voltage of the cells. Second, the logic

gates used form an SR latch. When both batteries are below the threshold level for their respective comparators, the latch will be set, forcing the part into shutdown. The latch is reset by pulling up on the RESET node, allowing the part to come out of shutdown.

The series resistance of a battery can cause its terminal voltage to rise as its current decreases. This effect can reset the low-battery detector and cause the LT1579 to oscillate between the primary and secondary inputs. To combat this, the low-battery comparators have up to 18mV of built-in hysteresis at the input to the comparator (LBI1, LBI2). The hysteresis is determined by the amount of load current on the comparator output. At no load, the comparator hysteresis is zero, increasing to a maximum of 18mV for load currents above 20µA. For the pull-up resistor shown, load current on the output of the comparator is 5µA, so hysteresis will be 5mV. With the values shown for resistor divider R2/R3, this translates to 19mV of hysteresis at the primary input of the LT1579. Additional hysteresis can be added by connecting

continued on page 24

High Efficiency Distributed Power Converter Features Synchronous Rectification

by Dale Eagar

Introduction

The advent of the switching regulator has greatly reduced the size, weight and volume of power conversion circuitry, while improving both the speed of response and efficiency. With the output voltage requirements going ever lower and currents ever higher, close scrutiny is applied to the loss mechanisms of the power converter. The loss mechanisms are caused by the circuit resistances (input capacitor ESR, power switch on-resistance, DC and AC resistance of the inductor, resistance of any current-sense elements, resistance in the output diode and ESR in the output capacitors) multiplied by the squares of their respective currents, and by fixed forward-voltage losses in the output diode, multiplied by the diode current. As output current goes up, the first thing to do is minimize all losses caused by resistance (because the power is proportional to I^2R). It is easy to minimize resistance because we have available very low ESR capacitors, low on-resistance MOSFETs and low series-resistance inductors. We have controllers that place a very small voltage across the current sense resistors. Because we do such a good job of dropping the resistive loss mechanisms, the output diode forward-voltage drop becomes the greatest loss mechanism. This is how the mandate for synchronous rectification comes about. Synchronous rectification is achieved by replacing the output diode with a low on-resistance switch. With synchronous rectification, efficiencies are higher, and, more importantly, power dissipated in the switching power supply is lower, often eliminating the need for heat sinks and/or fans.

Introducing the LT1339

The LT1339 is the buck/boost converter that needs no steroids. As a full-featured switching controller, the LT1339 incorporates the features needed for system-level solutions. The unfortunate lack of such features in most PWM converters forces designers to grope for handfuls of jellybean components. The LT1339 has an innovative slope-compensation function that allows the circuit designer freedom in controlling both the slope and offset of the slope-compensation ramp. Additionally, the LT1339 has an average current limit loop that yields a constant output current limit, regardless of input and/or output voltage. The LT1339's RUN pin is actually the input to a precision comparator, giving the designer freedom to select an undervoltage lockout point and hysteresis appropriate for the design. The SYNC and SS (soft-start) pins allow simple solutions to system-level design considerations. Like all Linear Technology controllers, the LT1339 has anti-shoot-through circuitry that ensures the robustness that is demanded in real-world applications for medium and high power conversion.

For input voltages ranging from 12V to 48V and output voltages ranging from 1.3V to 36V, the LT1339 is a simple, robust solution to your power-conversion problems. The LT1339 is ideal for power levels ranging from tens of watts to tens of kilowatts. The LT1339 is straightforward and remarkably easy to use. This is one power converter that's not afraid of 20A, 50A or even 150A of load current.

Distributed Power

Figure 1 details a typical low voltage buck converter. This circuit has a V_{IN} range of 10V to 18V with configurable output current and voltage. This simple circuit delivers 250W of load power into a 5V load while maintaining efficiencies in the mid-nineties.

Higher Input Voltages

The circuit shown in Figure 1 is limited to 20V because of the maximum rating (Abs Max) of the LT1339 V_{IN} pin. The input voltage can be extended above 20V by inserting a 10V Zener diode where the asterisk (*) is shown in Figure 1. This will extend the input voltage of Figure 1's circuit up to 30V (the Abs Max rating of the MOSFETs).

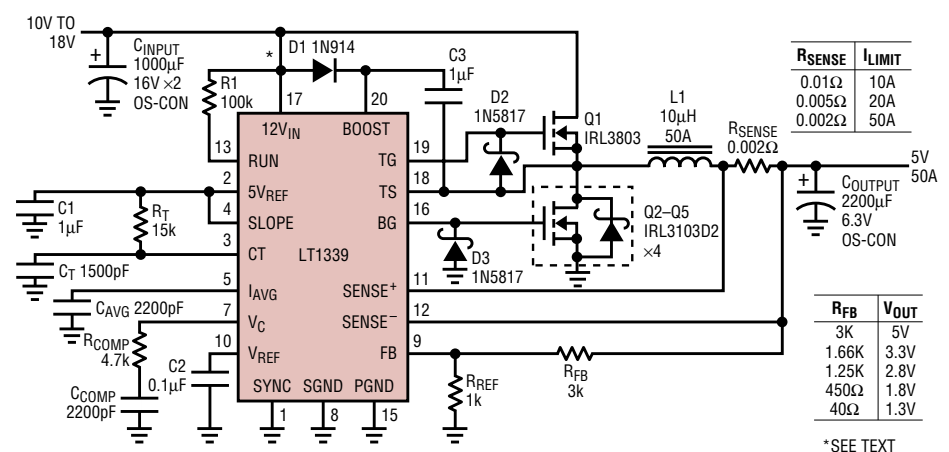

Figure 1. 10V-18V in, 5V/50A out buck converter

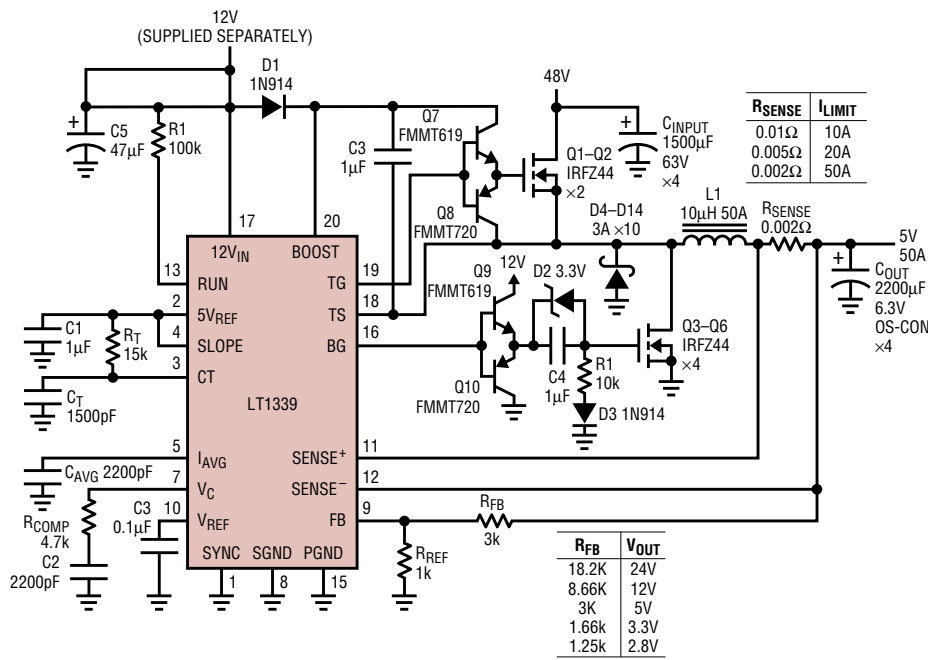

Figure 2. 48V in, 5V/50A out, high power buck converter

Blame it on the Physicists

As the input voltage approaches 30V, the bottom MOSFETs will begin to exhibit “phantom turn-on.” This phenomenon is driven by the instantaneous voltage step on the drain, the ratio of C_{MILLER} to C_{INPUT} , and yields localized gate voltages above V_T , the threshold voltage of the bottom MOSFET. To defeat the physicists, we add 3.3V of negative offset to the bottom gate drive, effectively making the threshold of the bottom MOSFETs 3.3V harder to reach (see Figure 2). This offset is provided by the 3.3V Zener, 1µF capacitor, 10k resistor and the 1N914 diode preceding the gate of the bottom MOSFETs.

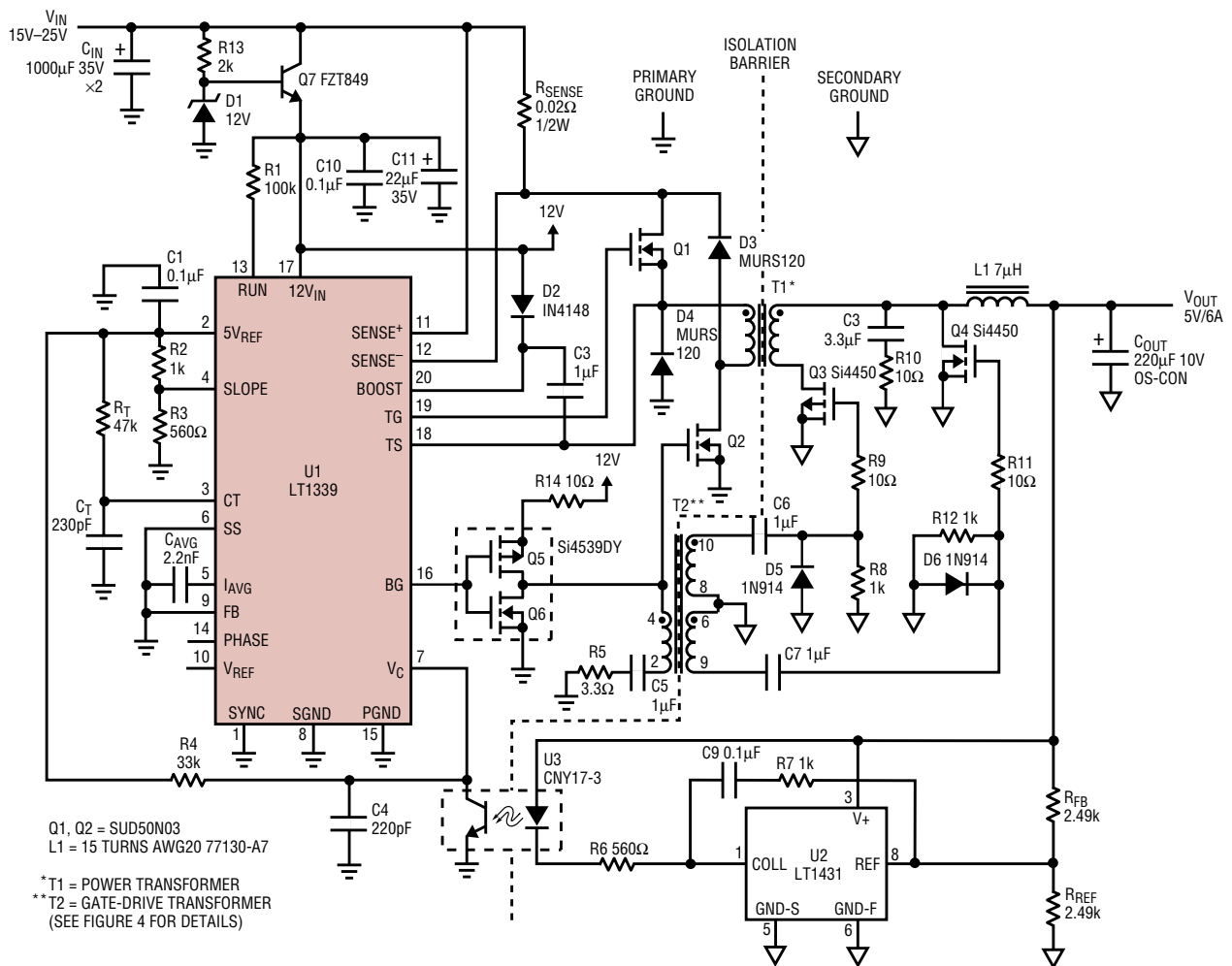

Figure 3. Galvanically isolated synchronous forward converter (See Figure 4 for details of T1 and T2.)

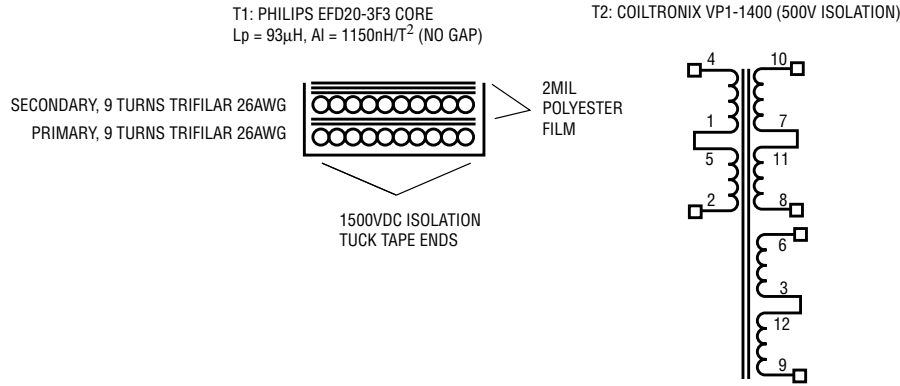

Figure 4. Transformer details of Figure 3's circuit

The Synchronous Forward Converter

The forward converter can be thought of as a buck converter with a transformer ratio. The transformer performs one or more of the following functions:

1. Increases the duty factor in converters with high transformation ratios, improving efficiency
2. Provides Galvanic isolation from input to output
3. Allows the converter to operate in the buck-boost mode, where the input voltage can be either higher or lower than the output voltage

Figure 3 details a Galvanically isolated LT1339 synchronous forward converter. Operating at its rated load of 6V at 5A, this circuit achieves 87% efficiency with a 15V input and 85% efficiency with a 24V input. Figure 4 shows details of the transformers used in Figure 3's circuit.

The Synchronous Boost Converter

The LT1339 becomes a synchronous boost controller when the PHASE pin is grounded. Figure 5 details a 250W boost converter that outputs 28V at 9A from a 5V supply.

Conclusion

The LT1339, like the many other members of the Linear Technology power conversion family, is full featured and well suited to the power conversion needs found in the real world. This robust workhorse is finding itself designed into countless applications, including power distribution, telecom, automotive and even military applications. 

Authors can be contacted at (408) 432-1900

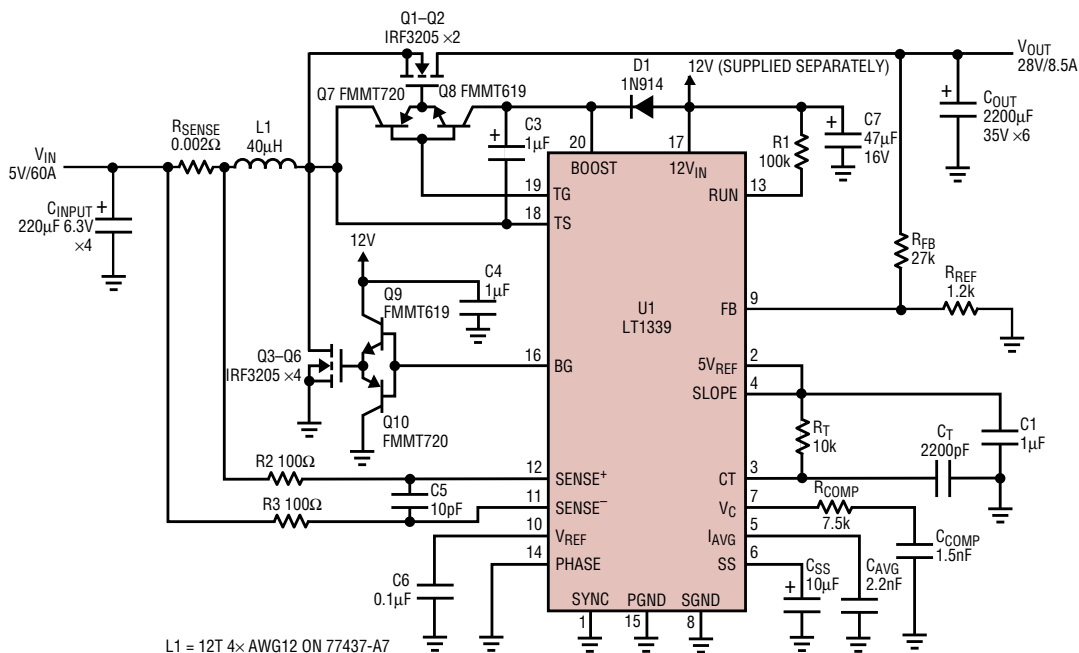

Figure 5. This 5V to 28V synchronous boost converter limits input current at 60A (DC).

LT1573, continued from page 17

capacitor and resistor form a zero that adds phase margin to the regulator system to prevent high frequency oscillation. The LT1573 has an internal pole at approximately 5kHz. An external compensation zero between 10kHz and 100kHz is usually required to stabilize the regulator. The zero frequency is primarily determined by the compensation capacitor and can be roughly calculated by the following equation:

$$f_{ZERO} = (40\text{kHz}) \frac{30\text{pF}}{C_{COMP}(\text{pF})} \quad 10\text{pF} \leq C_{COMP} \leq 100\text{pF}$$

A compensation resistor between 1k and 10k is suggested. A compensation resistor of 5k works for most cases. In some cases, a larger value compensation resistor in the suggested range is needed to stop oscillation above 1MHz. In some cases, the output capacitor may have enough equivalent series resistance (ESR) to generate the required zero, and the external compensation zero may not be needed.

Output Capacitor

The LT1573 is designed to be used with an external PNP transistor with a high gain-bandwidth product, f_T , to make a regulator with very fast transient response; this can minimize the size of the output capacitor. For a regulator consisting of an LT1573 and a D45H11, a single 10 μ F surface

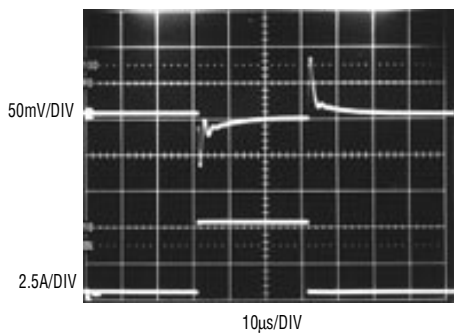



Figure 2. Transient response for a 0.2A to 5A step

mount ceramic capacitor at the output is enough to allow the regulator to handle varying output loads of up to 5A in a few hundred nanoseconds and to remain stable with a 30pF external compensation capacitor in series with a 7.5k resistor between the OUTPUT and COMPENSATION pins. If tighter voltage regulation is needed, more capacitance can be added to the regulator output. If more capacitance is added to the output, the bandwidth of the regulator will be lowered. A larger compensation capacitor may be needed to lower the frequency of the compensation zero to avoid high frequency oscillation. Equal-value output capacitors with different ESR can have different transient responses. High frequency response will be strongly affected by parasitics in the output capacitors and board layout. Some experimentation with the external compensation will be required for optimum results.

Typical Applications and Experimental Transient Response

A voltage regulator made with an LT1573 can be used as a microprocessor power source, post regulator for switching power supplies, high efficiency, high accuracy linear regulator or ultralow dropout regulator. A typical application circuit for a microprocessor power supply is shown in Figure 1. Figure 2 shows the output voltage transient of the circuit when the output load varies between 0.2A and 5A. About 80mV of transient deviation from 3.3V output (2.5%) can be observed.

Conclusion

The LT1573 provides a low cost solution to high current, fast transient, low dropout voltage regulator applications such as fast microprocessor power supplies. As a low dropout regulator, the LT1573 can provide load currents of up to 5A with dropout voltages as low as 0.35V. Because of its fast transient capability, the LT1573 cuts down the regulator cost by requiring much less bulk storage capacitance for tight voltage regulation. 

Authors can be contacted
at (408) 432-1900

LT1579, continued from page 20

D1 and R4. The values shown will give an additional 200mV of hysteresis.

When LBO1 and LBO2 are high impedance and either input is greater than 6.5V, the logic-flag voltages can be above the maximum voltage rating. Internal clamps on the logic flags limit the output voltage to approximately 6.5V and the pull-up resistor values shown will limit the current into the logic flags to less than the maximum current rating.

Conclusion

The LT1579 can provide a continuous regulated output voltage to critical

circuits from any of a number of different input sources. It will provide up to 300mA of output current at a dropout voltage of 0.4V. Should the primary input fail, the device switches seamlessly to the secondary input, maintaining output regulation. A single error amplifier controls both output stages so regulation remains tight regardless of which input is providing power. The LT1579 can handle instantaneous removal of either one of its inputs without losing regulation. System power management is aided by two status flags, which provide information about which input is providing power and signal the loss of

output regulation. Two independent low-battery comparators can be used to monitor input voltages. Also, an external pin can be used to force the switch to the secondary input. Total quiescent current of the LT1579 is 50 μ A, dropping to a mere 7 μ A in its low power shutdown state. Internal circuitry guards against a number of fault conditions, including current limit, thermal limit and reverse voltages, protecting sensitive circuitry and inputs. Whether the application is simple or complex, the LT1579 is truly a "smart" regulator. 

Single-Cell Li-Ion Battery Supervisor

by Albert Lee

Recently introduced precision products from Linear Technology allow designers to implement high precision applications at super-micropower levels. Among these devices are the LT1496 quad precision input/rail-to-rail output op amp and the LT1634 precision shunt voltage reference, which operate at only $1.5\mu\text{A}$ and $10\mu\text{A}$, respectively. Even at such low power levels, precision performance is not compromised. The LT1496 features $475\mu\text{V}$ maximum input offset voltage and 1nA maximum input bias current. The LT1634 achieves 0.05% initial accuracy and $25\text{ppm}/^\circ\text{C}$ maximum temperature drift.

Figure 1 shows a single-cell Li-Ion battery supervisory circuit. The building blocks of this circuit are the LT1496 precision op amp and LT1634 voltage reference. The useful region of operation of a single-cell Li-Ion battery is between 4.2V and 3V. The

cell voltage drops fairly quickly below 3V. System operation below this voltage can be erratic. Although Li-Ion battery use is becoming widespread, it is costly to damage the battery. The supervisory circuit protects the battery from overcharging and/or overdraining and prevents the battery voltage from falling out of its operating region. For instance, the LT1496 operates down to 2.2V, ensuring that circuit operation is maintained when the battery voltage falls below 3V.

The Li-Ion battery is monitored via a voltage divider off the battery voltage (node A). The divided voltage is fed into the positive inputs of comparators A2 and A3 and compared to the threshold voltages of 1.75V and 1.25V, respectively. These voltages are selected so that the minimum battery charge voltage is 3V and the maximum is 4.2V. The LT1634 1.25V reference is buffered by op amp A1.

The constant 1.25V across R2 creates a $1\mu\text{A}$ constant current, so that the output of A1 is amplified to 1.75V. This output drives R_S to provide constant bias current for the LT1634.

Depending on the battery voltage, the circuit is in one of the three states, as shown in Table 1.

The voltage at node A is compared to the two threshold voltages to determine the state of the circuit. For instance, when node A reaches or exceeds 1.75V (battery voltage reaches 4.2V), the outputs of A2 and A3 will swing to the positive rail, terminating the charger and connecting the load to the battery. When node A falls between 1.25V and 1.75V (battery voltage between 3V and 4.2V), the output of A2 swings low, turning the charger on, while the output of A3 stays high, leaving the load connected. When node A falls below 1.25V (battery voltage less than 3.0V), the output of A2 stays low, keeping the charger

DESIGN IDEAS

Single-Cell Li-Ion Battery Supervisor 25

Albert Lee

800mA Li-Ion Battery Charger Occupies Less Volume than Two Stacked Quarters 27

Fran Hoffart

Single-Supply Random Code Generator 29

Richard Markell

A Low Distortion, Low Power, Single-Pair HDSL Driver Using the LT1497 30

George Feliz and Adolfo Garcia

100V, 2A Constant-Voltage/Constant-Current Bench Supply 31

Mitchell Lee

Switcher Generates Two Bias Voltages without Transformer 32

Jeff Witt

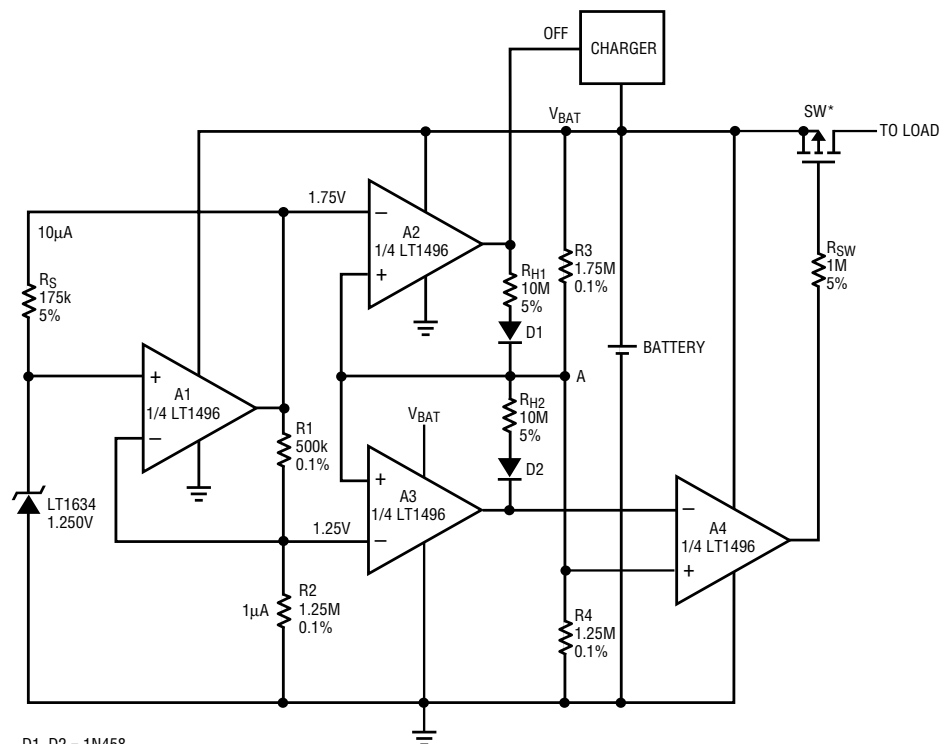

D1, D2 = 1N458
R1-R4 = CAR6 SERIES IRC (512) 992-7900
*TP0610L for 50mA LOAD

Figure 1. Single-cell Li-Ion battery supervisory circuit

Table 1. Circuit states

State	V _{BAT}	Node A	Output A2	Output A3	Output A4	Status
1	< 3V	< 1.25V	Low	Low	High	Load off, charge state
2	3V < V < 4.2V	1.25V < V < 1.75V	Low	High	Low	Load on, charge state
3	> 4.2V	> 1.75V	High	High	Low	Load on, charge terminated

on. The output of A3 will also swing low, which, in turn, will cause the output of A4 to go high, turning off FET SW that disconnects the load from the battery.

If node A were to bounce around at either threshold voltage, the circuit would bounce between states. To avoid this problem, hysteresis is added via the resistor and diode networks connected between the outputs of A2 and A3 and their positive inputs. Figure 2 shows the behavior of V_{BAT} vs node A entering the trip points with hysteresis. When V_{BAT} rises to 4.2V (node A increases to 1.75V), op amp A2's output will switch from low to high, causing current to flow through R_{H1}. The additional current will raise node A by an amount ΔV_{AHYS1}, which will clearly put the circuit in state 3. The circuit will not exit state 3 until V_{BAT} falls to ΔV_{HYS1} (310mV for the circuit shown) below 4.2V, which will cause node A to fall back to the upper trip point of 1.75V (point 1 of Figure 2). Similarly, when V_{BAT} drops below 3V (node A falls below 1.25V), op amp A3's output will switch low, causing current to conduct through R_{H2}. This will drag node A an amount ΔV_{AHYS2} below 1.25V, which will put the circuit in state 1. The circuit will not exit state 1 until the battery voltage is charged to an amount ΔV_{HYS2} (149mV for circuit shown) above 3V (point 2). This will bring node A back up to the lower trip

point, 1.25V, bringing the circuit out of state 1. The amount of hysteresis desired can be calculated using the following formulas:

High Trip Point:

$$V_{BAT} = (R3 \cdot (V_{OHMIN} + V_{BE} + 1.75V)/R_{H1} + 1.75V \cdot (R3/R4) + 1.75V)/(1 + R3/R_{H1})$$

$$\Delta V_{HYS1} = 4.2V - V_{BAT}$$

Low Trip Point:

$$I_{RH2} = (1.25V - V_{OLMAX} - V_{BE})/R_{H2}$$

$$\Delta V_{HYS2} = I_{RH2} \cdot R3$$

where:

V_{OHMIN} = output voltage swing high (LT1496)

V_{OLMAX} = output voltage swing low (LT1496)

V_{BE} = diode voltage of 1N458

Using an automobile analogy, if the LT1496 op amp is the transmission of the circuit (switching from one state to the next), the LT1634 voltage reference is the engine. It not only generates the threshold voltages, but also the amount of error that the circuit will have. How much accuracy and error you get depends on the car you drive. Maximum input offset voltage and input bias current for the LT1496 are 475μV and 1nA, respectively. The LT1634 is a 0.05% initial accuracy, 25ppm/°C tempco, 10μA precision shunt reference. Its 1.250V output voltage will appear at the input of A3 with an accuracy of 0.088%

(initial accuracy + input offset voltage). R1 and R2 being 0.1% resistors, the worst-case ratio error will be 0.2%. The worst-case voltage error across R1 will then be 0.2% or 1mV. This error on the 1.75V threshold voltage is 0.057%. Similarly, error at 1.75V due to worst-case 2nA input bias current is 0.057%. Total worst-case error at 1.75V will be 0.202%.

V_{BAT} error contributed by the voltage divider branch will consist of three terms: resistor matching, op amp input bias current and input offset voltage. The amount of error is different at the two trip points when V_{BAT} is 3V or 4.2V. Similar calculations as above result in 0.328% when V_{BAT} = 3V and 0.268% when V_{BAT} = 4.2V. Therefore, total battery voltage error at either trip points is better than 0.47%. Since only the ratios of R1 to R2 and R3 to R4 are critical, precision matched resistors with ten times better performance can be used to reduce the overall error by 33%.

This supervisory circuit demonstrates unparalleled performance achievable only with Linear Technology's supermicropower precision devices. The supervisory circuit consumes only 20μA. Battery voltage monitoring and control accuracy is better than 0.5%. **LT**

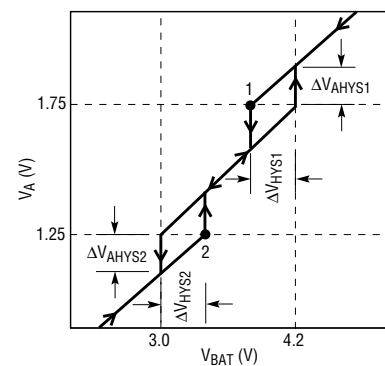

Figure 2. V_{BAT} vs V_A with hysteresis

Authors can be contacted at (408) 432-1900

800mA Li-Ion Battery Charger Occupies Less Volume than Two Stacked Quarters

by Fran Hoffart

Each new generation of cell phones, PDAs, portable instruments and other handheld devices is invariably more powerful, smaller and, most likely, thinner than the last. The circuit shown in Figure 1 is designed to charge one or two Lithium-Ion cells at currents up to 800mA, with all components equal to or less than 2.2mm (0.086 inches) tall. Using 0.031 inch PC board material, the total circuit thickness for this charger is 3.4mm (0.136in) or the thickness of two quarters. The complete 800mA constant-current/constant-voltage charger, including the PC board, occupies less volume than two quarters. This compact, low profile construction is ideal for cell phones or other applications where circuit height is restricted.

LT1510-5CGN High Efficiency 500kHz Switch Mode Battery Charger IC

The charger consists of an LT1510 constant-voltage/constant-current PWM IC, which includes an onboard 1.5A switch. The LT1510 is available in either 200kHz or 500kHz versions; the higher frequency version allows lower value, smaller-sized inductors to be used. An internal 0.5% reference allows precision battery-voltage programming and a current programming pin allows a single resistor, PWM signal or a programming current from a DAC to control the charging current. Also included are undervoltage lockout and a low quiescent current sleep mode that is activated when input power is removed.

The internal NPN switch achieves low saturation voltage by using a bootstrapped base-drive technique. A low boost voltage is bootstrapped to the switch pin to generate a base-

drive voltage that is greater than the input voltage. The ideal boost voltage is from 3V to 5V. If a single lithium cell is being charged, the battery voltage can be used for the boost voltage, but for two or more cells, a separate 3V source is recommended for maximum efficiency.

Fused-Lead Package Offers Lower Thermal Resistance

The LT1510-5 is available in a specially constructed 16-lead plastic SSOP package that has the die-attach paddle connected (fused) directly to the four corner leads and fits in the same area as an SO-8 package. This low profile fused-lead package provides a lower thermal resistance by conducting much of the heat generated by the die through the copper leads to the PC board copper. To take advantage of the improved thermal properties of this fused-lead package, it is important to provide as much PC board copper around the package leads as is practical. Back-side copper and internal copper layers

interconnected by feed-through vias all contribute to the overall effectiveness of the PC board used as a heat sink. Other heat-producing surface mount components, such as Schottky diodes and the inductor, also rely on the PC board copper to conduct heat away from the components.

Although the actual component area required for the charger can be as low as 0.72in², it is very likely that additional copper area may be needed to maintain component temperatures at safe levels. The amount of copper area required depends on factors such as maximum ambient temperature, airflow, input voltage and charging current. The LT1510-5 can be programmed for higher charging currents, but package and PC board thermal constraints will determine the maximum output current.

Selecting Thin Components

Some components are inherently thin (resistors, ceramic capacitors, diodes and transistors) but others are more difficult to make thin (inductors;

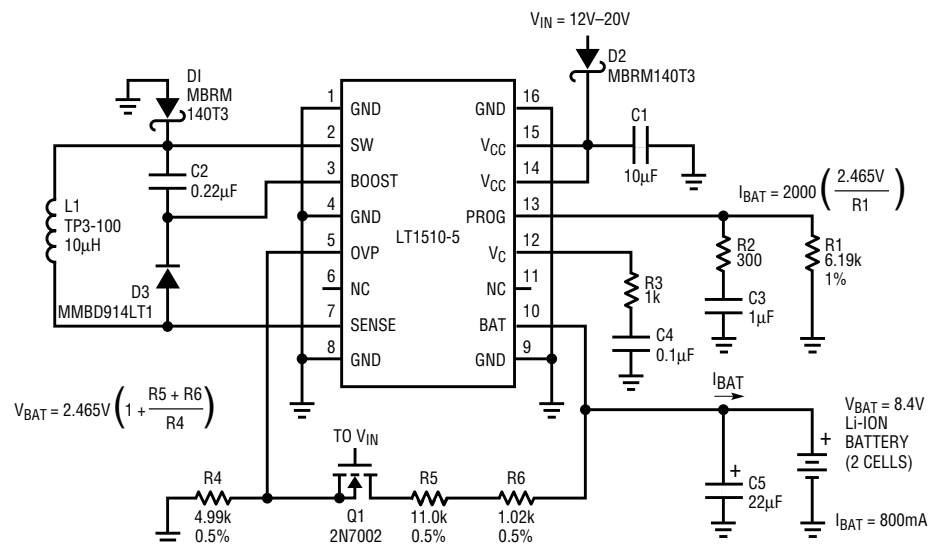

Figure 1. Compact, low profile, constant-current/constant-voltage charger for Li-Ion batteries

electrolytic and tantalum capacitors). The inductor used in this design is a very thin Coiltronics 10 μ H gapped toroid made of ferrite material, measuring 2.2mm (0.086in) in thickness. Other thicknesses, from 1.8mm to 3mm, are also available in the Coiltronics Thin-Pac™ line of inductors.

High dielectric-constant ceramic chip capacitors are used for C1 through C4. C1 is a Y5U type, selected because of its small size and high RMS current capability; X7R type material is selected for C2 through C4 because of its better temperature and voltage coefficients. The output capacitor, C5, is a special polymer aluminum electrolytic surface mount capacitor with a package height of 1.8mm. Available from Panasonic, this solid electrolyte capacitor features

small size, low ESR, high RMS current rating and long life.

Even standard SO packages for ICs are thicker than the 2.2mm limit required for this design; fortunately, the LT1510-5 is available in an SSOP package (GN package), which has a maximum height of only 1.75mm (0.069in.).

D1 and D2 are Motorola PowerMite® 1A, 40V Schottky diodes with a maximum package height of 1.15mm. Although these diodes are very small, they are rated for 1A, provided there is sufficient PC board copper surrounding the leads to provide a heat path for the power dissipated in the diodes. D3 is a small-signal silicon diode in a SOT-23 package with a maximum package height of 1.1mm. Also available in a SOT-23 package is

MOSFET Q1, which is used as an output-divider disconnect switch to prevent the divider current from discharging the battery when input power is removed.

Charger Operation

A typical charge profile for a discharged Li-Ion battery is an initial constant-current charge at 800mA until the battery voltage rises to the programmed voltage. It then changes to a constant-voltage charge, with the charging current gradually decreasing to near 0mA as the battery approaches full charge. If complete charge termination is required, pulling the V_C pin low or sinking zero current from the program pin stops the charge current. These signals could be supplied by an external timer or microprocessor.

When the input power is removed, the LT1510-5 goes into a low quiescent current (3 μ A) sleep mode, with this current coming from the battery. This low battery drain current allows the battery to remain connected to the charger for an extended period of time without appreciably discharging the battery. Additional battery-drain current can result from reverse leakage current in the Schottky catch diode D1. Many Schottky diodes have relatively high leakage currents, so care must be exercised in their selection.

Refer to the LT1510 data sheet for complete product specifications and to design notes DN111 and DN124 and application note AN68 for additional application information.

Conclusion

A compact, low profile Lithium-Ion battery charger using all surface mount components has been described. With a total circuit height of only 3.2mm (0.136in.) including PC board, this circuit can charge one or two Lithium-Ion cells at currents up to 800mA. Other battery chemistries can also be charged, although charge termination circuitry will be required if fast charging is used. 

Table 1. Low-profile components used in Figure 1's circuit

Reference Designator	Quantity	Part Number	Description	Vendor	Phone
C1	1	THCR50E1E106ZT	10 μ F, 25V, 20% Y5U Ceramic	Marcon	(847) 696-2000
C2	1	12063C224MAT1A	0.22 μ F, 25V, 20% X7R Ceramic	AVX	(207) 282-5111
C3	1	0805ZC105MAT	1 μ F, 10V, 20% X7R Ceramic	AVX	(207) 282-5111
C4	1	08055G104MAT1A	0.1 μ F, 50V, 20% X7R Ceramic	AVX	(207) 282-5111
C5	1	EEFCD1B220R	22 μ F, 12.5V, 20% Polymer Aluminum Electrolytic	Panasonic	(408) 945-5660
D1, D2	2	MBRM140T3	1A, 40V Schottky	Motorola	(800) 441-2447
D3	1	MMBD914LT1	0.2A 100V Silicon	Motorola	(800) 441-2447
L1	1	TP3-100	10 μ H Thin-Pac	Coiltronics	(561) 241-7876
Q1	1	2N7002	SOT-23 N-Channel MOSFET	Zetex	(516) 543-7100
R1	1		6.19k, 1% Chip Resistor	IRC	(512) 992-7900
R2	1		300 Ω , 5% Chip Resistor	IRC	(512) 992-7900
R3	1		1k, 5% Chip Resistor	IRC	(512) 992-7900
R4	1		4.99k, 0.5% Chip Resistor	IRC	(512) 992-7900
R5	1		11.0k, 0.5% Chip Resistor	IRC	(512) 992-7900
R6	1		1.02k, 0.5% Chip Resistor	IRC	(512) 992-7900
U1	1	LT1510-5CGN	Battery Charger IC	LTC	(408) 432-1900

Thin-Pac is a trademark of Coiltronics, Inc. PowerMite is a registered trademark of Motorola Corp.

Single-Supply Random Code Generator

by Richard Markell

Introduction

With the proliferation of satellite receivers, cable systems and Internet commerce, there is a need for secure encryption. A pseudorandom code generator that filled the bill several years ago is now considered "hackable" by many knowledgeable people.

Presented here is a truly random code generator that operates from a single supply. The circuit allows operation from a single 5V supply with a minimum of adjustments.

The circuit produces random ones and zeroes by comparing a stream of random noise generated in a Zener diode to a reference voltage level. If the threshold is correctly set and the time period is long enough, the noise will consist of a random but equal number of samples above and below threshold.

That Fuzz is Noise

The circuit shown in Figure 1 is the random noise generator. Optimum noise performance is obtained from a 1N753A Zener diode, which has a 6.2 volt Zener "knee." The diode is used to generate random noise. We have found that optimum noise output for this diode occurs at the "knee" of the I-V curve, where the Zener just starts to limit voltage to 6.2 volts.

Operating a 6.2V Zener from a 5V supply required some thought. Obviously, some type of voltage boosting scheme was needed to provide the diode with the 8V or more that it requires in this circuit. U1, an LTC1340 low noise, voltage-boosted varactor driver, provides 9.2V at 20 μ A from an input of 5V. This Zener current is the optimal for noise output from the diode (at 20 μ A the output is about 20mV_{P-P}).

The 1M and 249k resistors bias the input to operational amplifier U2 to 1.25V to match the input common mode range of comparator U3. The 1 μ F capacitor provides an AC path for the noise. Note: be careful where you place any additional capacitors in this part of the circuit or the noise may be unintentionally rolled off. This is one circuit where noise is desirable.

U2 is an LT1215 23MHz, 50V/ μ s, dual operational amplifier that can operate from a single supply. It is used as a wideband, gain-of-eleven amplifier to amplify the noise from the Zener diode; the second op amp in U2 is unused. U3, an LT1116 high speed, ground-sensing comparator, receives the noise at its positive input. A threshold is set at the negative comparator input and the output is adjusted via the 2k potentiometer for an equal number of ones and zeroes.

continued on page 36

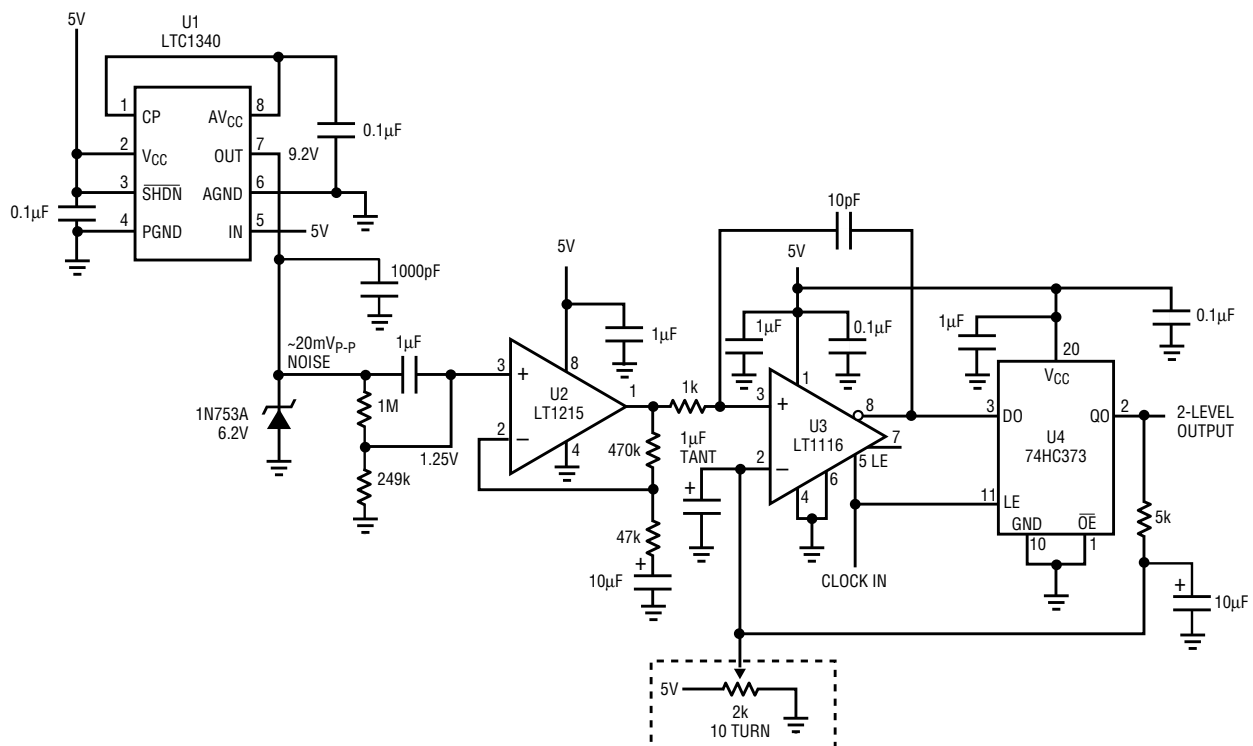

Figure 1. Single-supply random code generator

A Low Distortion, Low Power, Single-Pair HDSL Driver Using the LT1497

by George Feliz and Adolfo Garcia

Introduction

High speed digital subscriber line (HDSL) interfaces support full-duplex data rates up to 1.544Mbps over 12,000 feet using two standard 135Ω twisted-pair telephone wires. The high data rate is achieved with a combination of encoding 2 bits per symbol using two-binary, one-quaternary (2B1Q) modulation, and sophisticated digital signal processing to extract the received signal. This performance is possible only with low distortion line drivers and receivers. In addition, the power dissipation of the transceiver circuitry is critical because it may be loop-powered from the central office over the twisted pair. Lower power dissipation also increases the number of transceivers that can be placed in a single, non-forced-air enclosure. Single-pair HDSL requires the same performance as two-pair HDSL over a single twisted pair and operates at twice the fundamental 2B1Q symbol rate. In HDSL systems that use 2B1Q line coding, the signal passband necessary to carry a data rate of 1.544Mbps is 392kHz. This signal rate will be used to quantify the performance of the LT1497 in this article.

Low Distortion Line Driver

The circuit of Figure 1 transmits signals over a 135Ω twisted pair through a 1:1 transformer. The LT1497 dual 125mA, 50MHz current feedback amplifier was chosen for its ability to cleanly drive heavy loads, while consuming a modest 7mA maximum supply current per amplifier in a thermally enhanced SO-8 package. The driver amplifiers are configured in gains of two (A1) and minus one (A2) to compensate for the attenuation inherent in the back-termination of the line and to provide differential drive to the transformer. The transmit power requirement for HDSL is 13.5dBm (22.4mW) into 135Ω, corresponding to a 1.74V_{RMS} signal. Since 2B1Q modulation is a 4-level pulse amplitude modulated signal, the crest factor (peak to RMS) of this signal is 1.61. Thus, a 13.5dBm, 2B1Q modulated signal yields 5.6V_{P-P} across the 135Ω load. The corresponding output signal current is ±20.7mA peak. This modest drive level increases for varying line conditions and is tested with a standardized collection of test loops that can have line impedances as low as 25Ω. The LT1497's high output current and voltage swing drive the 135Ω line at the required distortion

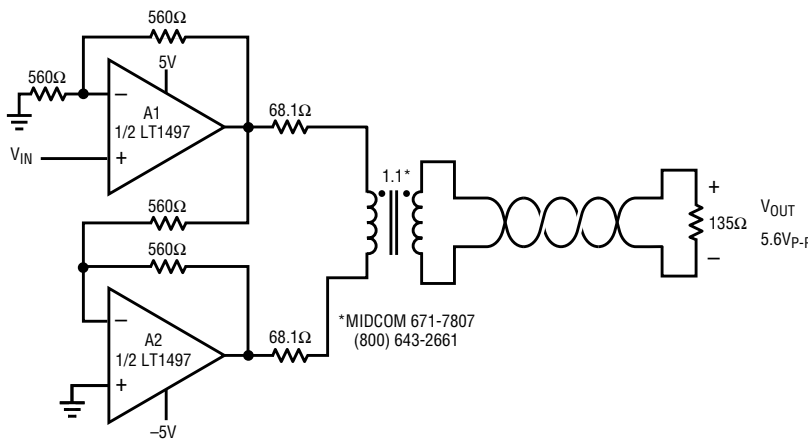

Figure 1. LT1497 HDSL driver

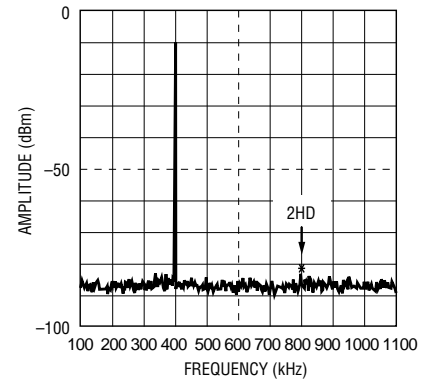

Figure 2. Harmonic distortion of Figure 1's circuit with a 400kHz sine wave and an output level of 5.6V_{P-P} into 135Ω

level of -72dBc. For a data rate of 1.544Mbps and 2-bit-per-symbol encoding, the fundamental frequency of operation is 392kHz.

The LT1497 provides such low distortion because it operates at only a fraction of its output current capability and is well within its voltage swing limitations. There are other LTC amplifiers that can achieve this performance, but at the expense of higher power dissipation or a larger package.

Performance

The circuit of Figure 1 was evaluated for harmonic distortion with a 400kHz sine wave and an output level of 5.6V_{P-P} into 135Ω. Figure 2 shows that the second harmonic is -72.3dB relative to the fundamental for the 135Ω load. Third harmonic distortion is not critical, because received signals are heavily filtered before being digitized by an A/D converter. Performance with a 50Ω load (to simulate more challenging test loops) is slightly better at -75dB. The output signal was attenuated to obtain maximum sensitivity of the HP4195A network analyzer used for the measurements.

With multicarrier applications such as discrete multitone modulation

continued on page 32

100V, 2A, Constant-Voltage/Constant-Current Bench Supply

by Mitchell Lee

Most engineering labs are well stocked with low voltage, moderate current power supplies, but higher voltage supplies capable of several amperes of output current are hard to find. I solved this problem in my lab by building the supply shown in Figure 1.

The circuit is based on U1, an LT1270 high efficiency switching regulator configured in a SEPIC topology, which allows the output to be adjusted higher or lower than the input voltage. Operation is similar to that of a flyback converter, but the primary and secondary windings are coupled

together by capacitor C1. This allows the primary and secondary windings to share current, reducing copper loss; it also eliminates the snubbing circuitry and losses found in flyback converters.

The converter is designed to operate from an input of 40V to 60V, supplied by a line transformer, diode bridge and filter capacitor (not shown). Output voltage is linearly adjustable from zero to 100V via potentiometer R20.

The current is limited by two independent loops. The first current limit loop is user controlled over a range of

zero to 8A by setting potentiometer R21. This setting does not interact with changes in output voltage. A second current limit loop limits the maximum available current as a function of voltage (components R1–R5 and U2), minimizing component stress. Under any given operating condition, the lower of the two loops takes control. Maximum available output current is highest at low output voltage settings (about 8A), and decreases to 2A at 100V output. 

Jesus Rosales played a significant role in the design, building and testing of this circuit.

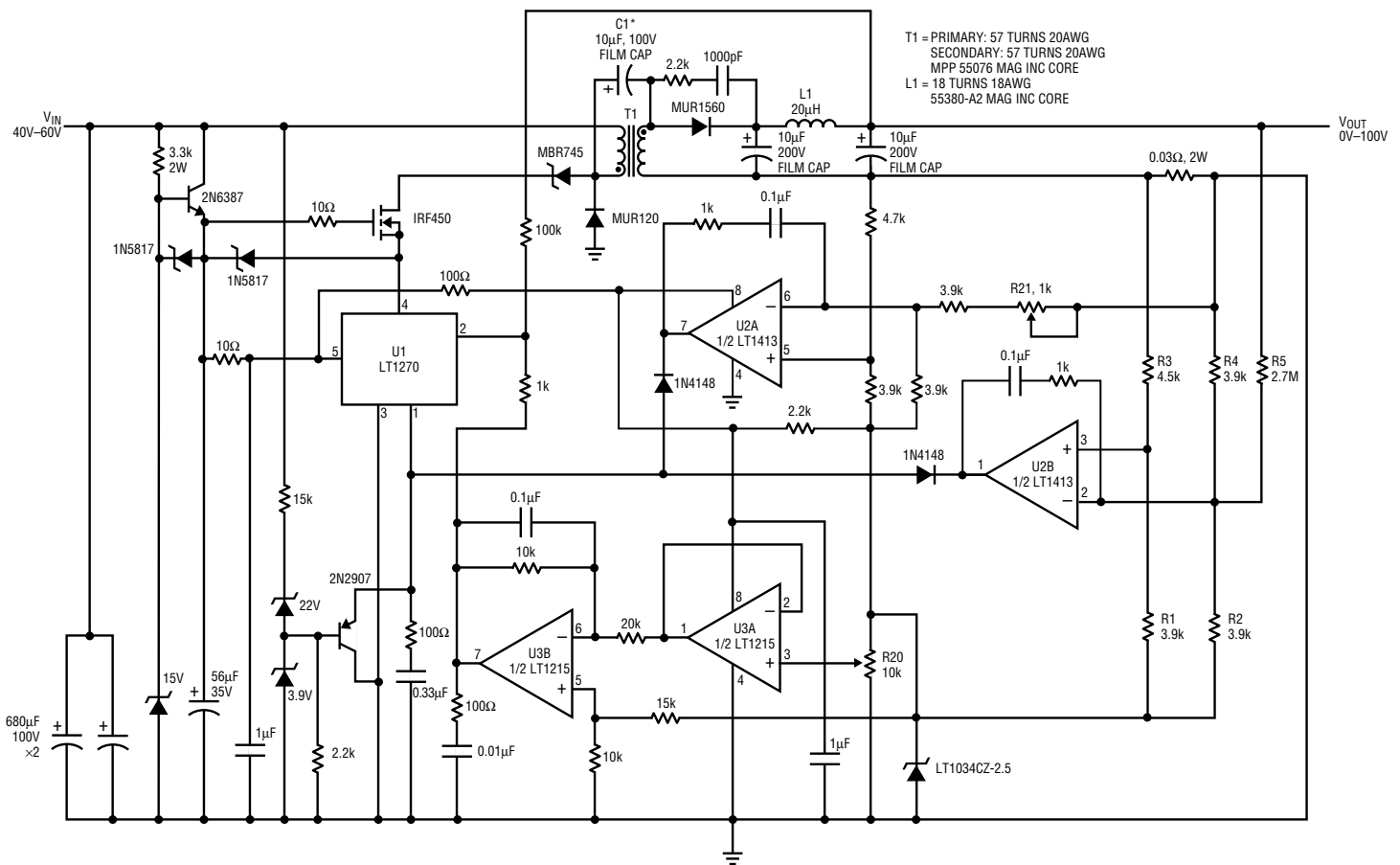

Figure 1. 100V/2A Constant Voltage/Constant Current Bench Supply

Switcher Generates Two Bias Voltages without Transformer

by Jeff Witt

LCD displays and CCD imaging circuits in today's portable products require several bias voltages from a 10V to 20V input at a few mA. When symmetric bipolar bias supplies are needed, the negative supply can be generated with a discrete charge pump operating from the power switch of the boost regulator that generates the positive supply. However, an asymmetric bipolar supply is typically required: for example 20V and -10V for LCD displays or 15V and -7.5V for CCDs. One possible solution is to add a linear regulator to the negative output; this adds cost and greatly reduces the efficiency of the switcher. Another possibility is a 2-output flyback circuit, but the added cost and bulk of a

transformer make this solution unappealing. The circuit in Figure 1 avoids these penalties, producing 20V at 5mA and -10V at 5mA from 3.3V with 73% efficiency. The circuit uses standard surface mount parts.

The LT1316, a micropower Burst Mode switching regulator with an integrated 0.6A power switch, operates in an ordinary boost circuit to generate the 20V (V_{OUT1}) set by resistor divider R1 and R2. An internal comparator at the FB pin regulates the output by gating the LT1316's oscillator. A charge pump (C2 and associated diodes) coupled to the LT1316's switch pin generates the negative output voltage. This negative output (V_{OUT2}) is monitored by

the LT1316's low-battery detector through the resistor divider R3 and R4, using the positive 20V output as a reference. When the negative output falls below 10V, the low-battery detector output (LBO pin and lowest trace in Figure 2) turns Q1 on, enabling the charge pump and charging output capacitor C4. Note that the switch pin jumps between ground and ~10V during this period. Once the negative output has been charged enough to overcome the low-battery detector's hysteresis, Q1 turns off and the switch pin is free to fly to 20V, charging the positive output.

This circuit can also operate directly from two alkaline or NiCd cells. Slightly higher peak currents are necessary; change R5, which determines the peak switch current of the LT1316, to 6.8k Ω and change L1 to 15 μ H. 

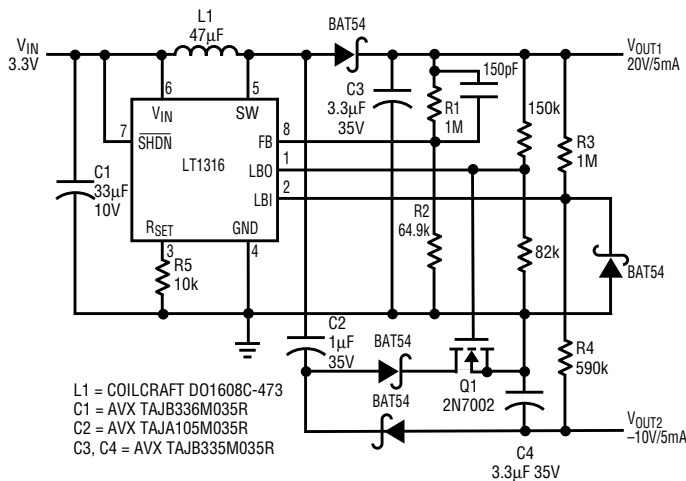

Figure 1. By gating the charge pump, this circuit generates a regulated negative output with a magnitude different from that of the positive output.

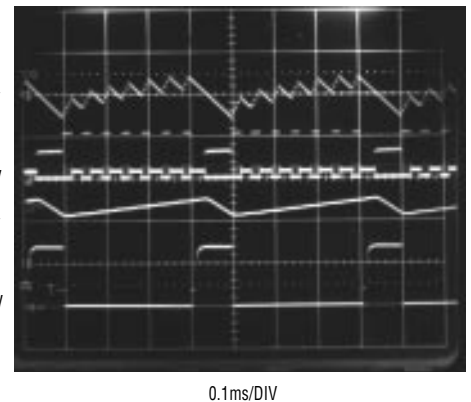

Figure 2. Voltage waveforms of Figure 1's circuit

HDSL Driver, continued from page 30

(DMT) becoming as prevalent as single-carrier applications, another important measure of amplifier dynamic performance is 2-tone intermodulation. This evaluation is a valuable tool to gain insight to amplifier linearity when processing more than one tone at a time.

For this test, two sine waves at 300kHz and 400kHz were used with levels set to obtain 5.6V_{P-P} across the 135 Ω load. Figure 3 shows that the

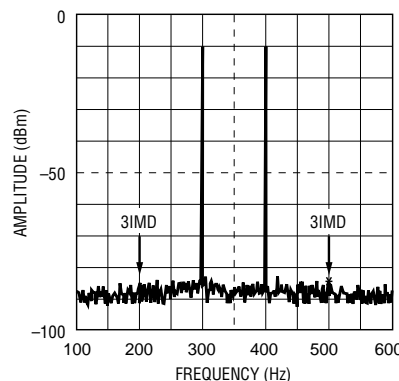



Figure 3. 2-tone intermodulation for Figure 1's circuit

third-order intermodulation products are well below -72dB. With a 50 Ω load, performance is within 1dB-2dB of that with the 135 Ω load.

Conclusion

The circuit presented provides outstanding distortion performance in an SO-8 package with remarkably low power dissipation. It is ideally suited for single pair digital subscriber line applications, especially for remote terminals. 

Reference Squeezes More Performance from Less Package

by John Wright

Introduction

The small outline transistor (SOT) package is used extensively for space sensitive, surface mount, discrete-transistor applications. Recently, several manufacturers have put voltage references into SOT packages, but the current crop sacrifices performance to fit into this stingy package. Simply put, the package and die area are so small that techniques used to design good references need modification. Today's applications demand more performance in smaller PC board space and the size of the SOT is ideal—the SOT footprint is 4.7 times smaller than the 8-pin SO package footprint. The challenge is to make a quality reference small enough to fit into the SOT package.

Voltage Reference or Precision Regulator

The LT1460S3 is a series reference that provides supply current and power dissipation advantages over shunt references, which must idle their entire load current to operate. This new reference uses curvature compensation to obtain low temperature coefficient, and laser-trimmed precision thin-film resistors to achieve high output accuracy. The manufacturing process used is a stepper-based, high speed bipolar process that was selected for its density.

The LT1460S3 uses a proprietary trim algorithm at wafer sort that guarantees less than 20ppm/°C temperature coefficient (typically 10ppm/°C). The temperature coefficient (TC) is affected by package stress during assembly, widening the distribution slightly. The result is three grades, two with guaranteed $TC \leq 20\text{ppm}/^\circ\text{C}$. This performance is something of a milestone, because the highest grade TC available in SOT heretofore was 50ppm/°C, and that is the lowest grade available on the LT1460S3. Low stress thin-film resistors and special layout techniques were used to achieve 0.2% maximum tolerance without the use of gel coat to protect the surface from stress. This combination of low TC and high accuracy makes the LT1460S3 capable of 8 bits of absolute accuracy over temperature without a system calibration.

The LT1460S3 supplies up to 20mA of output drive, making it ideal for precision regulator applications. It is stable with any value output capacitor, including zero, and this can be helpful in applications where PC board space is at a premium, or when fast settling is demanded. An output capacitor used for stability slows down the reference transient response. The LT1460S3 settles in 1 μs to 0.2% for a 100 μA pulse with no output capacitor and in just 2 μs for a 1mA pulse.

Measure It on a PC Board

Soldering a SOT reference onto a PC board is a harsh thing to do. The reference that leaves Linear Technology is within the data sheet specification, but the thermal shock of being soldered onto a PC board causes the reference to shift. The problem is that the short, stiff leads do not absorb stress and it is transferred to the die. Low stress thin-film resistors and careful layout techniques in the LT1460S3 reduce

solder-related shift to typically 0.02%. A graph of the output voltage after IR reflow solder is shown in Figure 1. After the part is soldered onto a PC board, the output voltage should not drift with time.

When an instrument manufacturer sends out a PC board for duty in the field, it has had extensive testing, perhaps a calibration, and its voltage reference is stable. Over time, however, the reference output voltage may change. This long-term drift is caused mainly by differential stress between the IC package and the PC board. This output shift is a nonlinear function of time, and is normally expressed in ppm/ $\sqrt{\text{kh}}$. What this means is that the shift in the first one thousand hours is more than that in the subsequent one thousand hours. Figure 2 shows a plot of long-term drift of the LT1460S3 soldered to a PC board. This part was measured in a 30°C oven that was controlled to $\pm 1^\circ\text{C}$. The long-term drift is the trend line created by this plot; over one thousand hours, this typical part moved 50ppm, or about 125 μV for the LT1460S3-2.5.

Hysteresis in the output voltage is another package-stress phenomenon. A reference output voltage does not return to exactly the same 25°C value after it has been at different temperatures. This is because the stress on

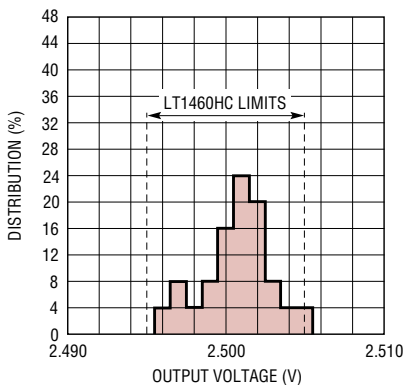

Figure 1. Typical distribution of SOT-23 LT1460HC V_{OUT} after IR reflow solder

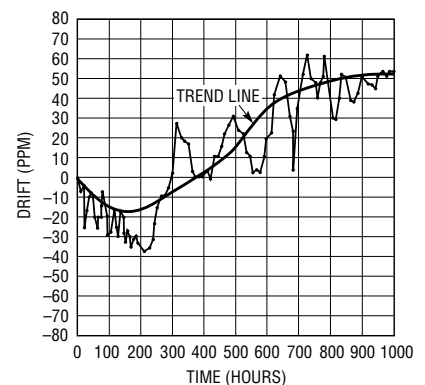

Figure 2. LT1460S3 long-term drift

the die changes with temperature and never returns to exactly the same state in which it started. Hysteresis is roughly an exponential function of the temperature excursion away from 25°C and depends on whether the IC was previously at a higher or lower temperature. The output voltage is always measured at 25°C, but the IC is cycled over its specified temperature range before successive measurements. The LT1460S3 has a typical hysteresis of 100ppm for a 0°C to 70°C excursion. Hysteresis increases

to 250ppm with a -40°C to 85°C temperature change because larger stress is associated with a larger temperature range. The initial accuracy specification of 0.2% includes a margin for hysteresis. This is because it is not possible to know what temperature changes the part may be subjected to on its way to the customer. Because hysteresis is increased by wider temperature excursions, the part may shift out of tolerance if is stored outside of the specified temperature range.

Summary

The LT1460S3's high output current, low temperature coefficient and excellent, yet conservative accuracy specification set a new standard for SOT voltage references. This new reference is available in 2.5V and 5V output voltages. For even tighter tolerance and lower temperature coefficient, the LT1460 is also available in MSOP, SO, PDIP and 3-lead TO-92 packages.

Authors can be contacted at (408) 432-1900

LTC1659, LTC1448: Smallest Rail-to-Rail 12-Bit DACs Have Lowest Power

by Hassan Malik

In this age of portable electronics, power and size are the primary concerns of most designers. The LTC1659 and the LTC1448 are rail-to-rail, 12-bit, voltage output DACs that address both of these concerns. The LTC1659 is a single DAC in an MSOP-8 package that draws only 250µA from a 3V or 5V supply, whereas the LTC1448 is a dual DAC in an SO-8 package that draws 450µA from a 3V or 5V supply.

Figure 1 shows a convenient way to use the LTC1659 in a digital control loop where 12-bit resolution is required. The output of the LTC1659 will swing from 0V to V_{REF} , because there is a gain of one from the REF pin to V_{OUT} at full-scale. Because the output can only swing up to V_{CC} , V_{REF} should be less than or equal to V_{CC} to prevent the loss of codes and degradation of PSRR near full-scale.

To obtain full dynamic range, the REF pin can be connected to the supply pin, which can be driven from a reference to guarantee absolute accuracy (see Figure 2). The LT1236 is a precision 5V reference with an input range of 7.2V to 40V. In this configuration, the LTC1659 has a wide output swing of 0V to 5V. The LTC1448 can be used in a similar configuration where dual DACs are needed.

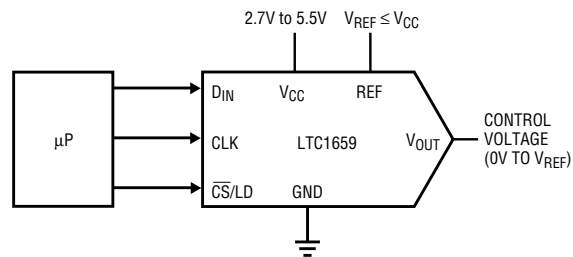

Figure 1. 12-bit DAC for digital control loop

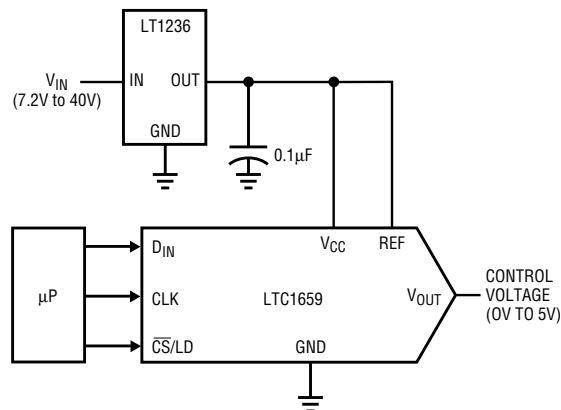

Figure 2. 12-bit DAC with wide output swing

LTC1197/LTC1199: New Micropower MSOP 10-Bit ADC Samples at 500ksps

by Guy Hoover and Marco Pan

Introduction

The LTC1197 and LTC1199 10-bit serial ADCs, recently released by Linear Technology, offer small size, low power operation and fast sample rates with good AC and DC performance. These parts are ideal for low power, high speed and/or compact designs. In this article, we will examine the features and performance of the LTC1197/LTC1199 that make these parts excellent choices for such new designs.

Features

Smallest Size (MSOP)

The LTC1197/LTC1199 are among the smallest ADCs available. The serial interface allows the LTC1197/LTC1199 to be offered in 8-pin packages. The MSOP package (an SO is also available) reduces the small footprint even further. These are some of the first ADCs available in the MSOP package, which is about half the size of the SO-8.

Flexible Inputs

The LTC1197 has a single differential input with an adjustable reference. The adjustable reference input allows the full scale to be reduced to as low

as 200mV. This translates to an LSB size of only 200 μ V. Combined with the high impedance of the analog input, this allows direct digitization of low level transducer outputs, which can save board space and the cost of a gain stage.

With its software-selectable 2-channel MUX, the LTC1199 is capable of measuring either one differential or two single-ended inputs. Both parts have a built-in sample-and-hold.

Serial I/O

Using either 3- or 4-wire serial interfaces, the LTC1197/LTC1199 are hardware and software compatible with both SPI and MICROWIRE protocols. This compatibility is achieved with no additional circuitry, allowing easy interface to many popular processors.

3V or 5V Supplies

The LTC1197/LTC1199 are 5V parts ($V_{CC} = 4V-9V$ for the LTC1197 and $4V-6V$ for the LTC1199). Also available for use in 3V systems are the LTC1197L and the LTC1199L ($V_{CC} = 2.7V-4V$). Designed for use in mixed-supply systems, the digital inputs of these devices can be taken above the V_{CC} voltage without damaging the ADC. This is useful in systems where the ADC is running at a lower supply voltage than the processor. If the ADC is running at a higher supply voltage than the processor, the ADC serial data output voltage can easily be decreased to a level appropriate for the processor.

To summarize, the LTC1197/LTC1199/LTC1197L/LTC1199L are a very flexible group of parts. They are capable of providing a designer with a small footprint, one or two channels,

single-ended or differential inputs, adjustable reference voltage, SPI-/MICROWIRE-compatible serial I/O and 3V or 5V operation.

Performance

Micropower Performance with Auto Shutdown at Full Speed

Now let's take a look at the performance of the LTC1197/LTC1199. Running continuously, the LTC1197L consumes only 2.2mW at the maximum sampling rate (25mW for the LTC1197). You can reduce the power consumption dramatically, as shown in Figure 1, simply by lowering the sampling rate. The formula for calculating power consumption is:

$$P_D = V_{CC} \cdot I_{CC} \cdot t_{CONV} \cdot f_S$$

where P_D is the power consumption, V_{CC} is the supply voltage, I_{CC} is the supply current while the conversion is occurring, t_{CONV} is the conversion time and f_S is the sample rate. As you can see from the formula, lowering f_S reduces the power consumption linearly. It is also important to minimize t_{CONV} by clocking the ADC at its maximum rate during the conversion. Although the ADC draws slightly more power at high clock rates, the total power is less because the device is on for a shorter period of time. For example, the 2.2mW is cut to 10.4 μ W by reducing the sampling rate from 210kHz to 1kHz. The calculation for power dissipation is as follows:

$$P_D = 2.7V \cdot 0.8mA \cdot 4.8\mu s \cdot 1kHz = 10.4\mu W$$

High Speed Capability

Even though the LTC1197/LTC1199 are capable of micropower operation, they are able to convert at rates of up

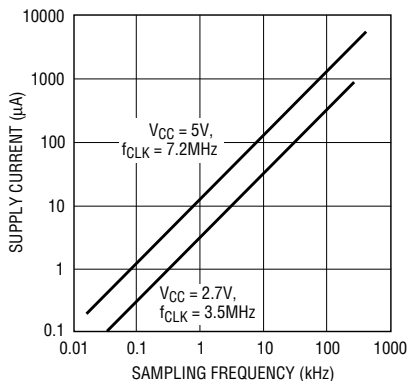

Figure 1. Supply current (I_{CC}) vs sampling frequency f_S

to 500kHz (210kHz for LTC1197L). These parts can also digitize fast input signals up to the Nyquist frequency (250kHz for the LTC1197) with over nine effective number of bits (ENOBs).

Good DC and AC Specs

The DC specifications of these parts are very good. Linearity (both INL and DNL) is typically 0.3LSB with a maximum spec of 1LSB. Offset is specified at 2LSBs (Max) and gain error is specified at 4LSBs (Max). These speci-

fications are guaranteed over the full temperature range of the part. Both commercial and industrial temperature range versions are available.

AC performance is equally impressive. $S/(N+D)$ is typically 60dB (58dB for the L version). THD is typically -64dB (-60dB for the L version) and the peak harmonic or spurious noise is typically -68dB (-63dB for the L version). The L version has slightly degraded specifications due to the smaller dynamic range and the higher internal noise of the ADC at its lower operating current.

Conclusion

We have seen that the LTC1197 and LTC1199 have a small footprint and are capable of micropower operation. These parts have a versatile serial interface that is SPI/MICROWIRE compatible. The adjustable reference input, 2-channel, software-selectable MUX and 5V or 3V operation add to the versatility of this ADC family. When this versatility is combined with the high conversion rate and good DC and AC performance, you can see why these ADCs are good choices for low power, high speed and/or compact designs. 

Random Code, continued from page 29

The 5k resistor and the 10 μ F capacitor provide limited hysteresis so that the adjustment of the potentiometer is not as critical. Latch U4, a 74HC373, ensures that the output remains latched throughout one clock period. The circuit's output is taken from U4's Q0 output.

Some Thoughts on Automatic Threshold Adjustment

Several circuit designers have asked about threshold adjustment without manual knobs or potentiometers. One way to implement this would be to have the microprocessor count the number of ones and zeroes over a given time period and adjust the threshold (perhaps via a digital pot) to produce the required density of ones.

A more "analog" method of adjusting threshold might be to implement an integrator with reset. This circuit integrates the number of ones and zeroes over time to produce a zero result for an adjustment that produces equal numbers of ones and zeroes. Again, a digital pot could be used to adjust threshold, with the threshold being decreased for the case of "not enough ones" and increased for the case of "too many ones."

After many more conversations with the "cyber illuminati," the circuit in Figure 2 was devised. This circuit can be used to replace the pot shown in the dashed box in Figure 1. In

operation, an LT1004-2.5 is used as a reference at the front end of a precision voltage divider string. A series of voltages is generated along the divider string and a jumper is used to connect this voltage to a buffer and then to the negative input of the LT1116 comparator. As was the case with the 2k pot, the voltage at pin 2 (the negative input of the comparator) sets the threshold for the comparator. The selection of voltage taps on the resistor

string is arbitrary; they were selected to allow a good adjustment range (defined as allowing jumper adjustment to 50% ones and 50% zeros) for a sample of ten 1N753A Zener diodes used to produce noise. The jumper could (and probably should) be replaced with analog switches controlled by a microprocessor in medium- to high-volume applications. 

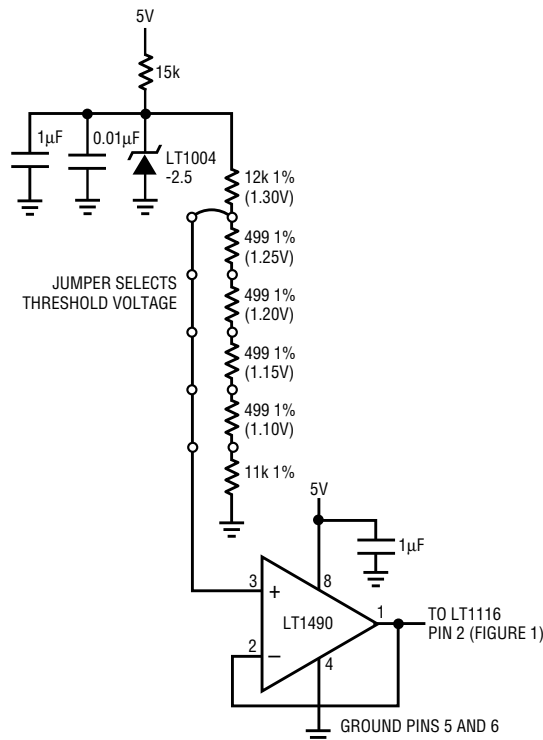

Figure 2. Jumper selects threshold for Figure 1's circuit

New Device Cameos

LTC1660 Micropower, Octal, 10-Bit DAC with Sleep Mode

The LTC1660 sets a new standard in DAC density by integrating eight high quality addressable 10-bit DACs in a single, tiny 16-pin package, no larger than an SO-8: required board area is only 0.006in² per DAC.

Operating on a single 2.7V–5.5V supply rail, the LTC1660 draws just 60μA per DAC (480μA for all eight), for true micropower performance. Sleep mode further reduces total supply-plus-reference current to just 1μA.

The LTC1660 is guaranteed monotonic over temperature—DNL error is typically ±0.2LSB (±0.5LSB Max). Each of the rail-to-rail output amplifiers can source or sink up to 5mA. The outputs swing to within a few millivolts of either supply rail when unloaded and have an equivalent output resistance of 80Ω when driving a load to the rails. The output amplifiers are stable driving capacitive loads up to 1000pF.

The 3-wire serial interface uses a 16-bit input word comprising four address/control bits, ten input-code bits, and two don't-care bits. Asynchronous CLR, power-on reset and daisy-chain capability are also provided. It is possible to keep one or more chips in a daisy chain in continuous Sleep mode by giving the Sleep instruction to these chips each time the active chips in the chain are updated.

Ultralow supply current, power-saving Sleep mode and extremely compact size make the LTC1660 ideal for battery-powered applications; its straightforward usability, high performance and low cost make it an excellent choice as a general-purpose converter.

LTC1234: Low Dropout Regulator with Comparator and Shutdown

The LTC1234 combines a micropower, positive, low dropout linear regulator and a low-battery comparator. With only 20μA quiescent current, typical dropout voltages are 250mV for 5V output with 500mV of load, or 150mV for 3.3V with 250mA of load. An internal 750mA P-channel pass transistor draws no base current, allowing the device to draw less than 35μA of quiescent current over the extended temperature range, independent of load current.

Protection circuitry protects against output short circuits, thermal overloads and reverse current when the input potential falls below the output.

A micropower comparator with an open drain output can be used for system or battery monitoring. The SD pin allows the regulator to be shut down while the comparator and reference remain alive. The quiescent current drops down to 5μA in shutdown mode.

The LTC1234 is available in the 8-pin SO wide package.

LTC1068-XX: New Family of Quad Universal, Switched Capacitor Filter Building Blocks

The LTC1068-XX consist of four identical, low noise, switched capacitor filter building blocks. Each building block, together with three to five resistors and an external clock, provides 2nd order filter functions such as lowpass, bandpass, highpass and notch.

High precision quad 2nd order, dual 4th order or single 8th order filters can be designed with an LTC1068-XX. All these devices are fully supported by the new Filter-CAD™ for Windows® filter design software.

An external clock tunes the center frequency of each filter building block. The clock-to-center frequency ratio is internally set to 25:1 (LTC1068-25), 50:1 (LTC1068-50) or 200:1 (LTC1068-200). The clock-to-center frequency ratio can also be modified with external resistors. The internal sampling rate of all the LTC1068-XX devices is twice the clock frequency. This allows the frequency of input signals to approach twice the clock frequency before aliasing occurs. The LTC1068-XX is designed to complement the LTC1068, which features a 100:1 clock-to-center frequency ratio.

The LTC1068-200, with its internal 400:1 sampling-rate-to-center-frequency ratio behaves almost like a continuous time filter; it is recommended for non-band-limited filter circuits such as highpass and notch. Notch filters with 80dB notch depth can be easily realized.

The LTC1068-50 is aimed at filter applications, especially lowpass and bandpass, requiring single 3V to 5V supply and low power consumption. The LTC1068-50 consumes 3mA typical.

The LTC1068-25 lowers its internal clock-to-center frequency ratio so it can achieve 200kHz cutoff frequencies with a 5MHz clock.

The LTC1068-XX family is available in 28-pin SSOP. Demo boards are also available to qualified customers.

A customized version of the LTC1068-XX in a 16-lead SO with internal thin-film resistors can be ordered. Please contact LTC marketing for details.

LTC1541/LTC1542: Micropower Op Amp, Comparator and Reference

The LTC1541/LTC1542 combine a micropower amplifier, comparator and bandgap reference (LTC1541 only) in an 8-pin package. These parts operate from single supplies of 2.5V to 12.6V or dual supplies of $\pm 1.25\text{V}$ to $\pm 6.3\text{V}$, with a typical supply current of $6\mu\text{A}$. Both the op amp and comparator feature a common mode input voltage range that extends from the negative supply to within 1.3V of the positive supply. The output stages swing from rail-to-rail. The comparator's inverting input is internally connected to the reference output (LTC1541) or bonded out without the reference (LTC1542).

The reference output voltage is 1.2V $\pm 1\%$ over the extended temperature range (-40°C to 85°C). The output can drive a bypass capacitor of up to $0.01\mu\text{F}$ without oscillation. It can also source up to 2mA and sink up to $20\mu\text{A}$.

The op amp is internally compensated to be unity-gain stable, with a

typical gain bandwidth of 10kHz and a typical slew rate of 8V/ms. The comparator has $\pm 3\text{mV}$ of internal hysteresis to ensure clean output switching even with slow moving input signals.

The LTC1541/LTC1542 are available in 8-pin SO and MSOP packages.

LTC1562 Quad Universal Active Filter with SNR >100dB

The LTC1562 is a new low noise, low distortion, DC-accurate, continuous-time filter block with rail-to-rail inputs and outputs, optimized for 50kHz–200kHz applications (other cutoff frequency ranges are available by custom order). It contains four matched, independent 2nd order filter sections, which can be cascaded in any combination, such as one 8th order or two 4th order filters. Each section's response is programmed with three external resistors, for center frequency, Q and gain, and each section provides lowpass and bandpass out-

puts. A highpass response is available if one of the resistors is replaced with an external capacitor. Center frequency is internally trimmed to $\pm 0.5\%$ and is very stable with temperature. A shutdown pin puts the chip into "zero-power" shutdown state.

Operating from single or dual power supplies of 4.75V to 10.5V total, the LTC1562 is designed for applications where dynamic range is critical, such as receivers, data modems and DSP antialiasing or reconstruction. With $\pm 5\text{V}$ supplies and $Q = 1$, a 2nd order section delivers a typical signal-to-noise ratio (SNR) of 103dB, total harmonic distortion of -96dB and DC offset of 2mV. In applications that filter signals of wide amplitude range, it is possible to use the LTC1562's gain-setting resistor for gain control, which reduces the input noise at higher gains and extends the dynamic range (maximum signal to minimum noise) to 118dB.

The LTC1562 is offered in 16-pin DIP and 20-pin SSOP packages. 



For further information on any of the devices mentioned in this issue of *Linear Technology*, use the reader service card or call the LTC literature service number:

1-800-4-LINEAR

Ask for the pertinent data sheets and Application Notes.

DESIGN TOOLS

Applications on Disk

Noise Disk — This IBM-PC (or compatible) program allows the user to calculate circuit noise using LTC op amps, determine the best LTC op amp for a low noise application, display the noise data for LTC op amps, calculate resistor noise and calculate noise using specs for any op amp. Available at no charge

SPICE Macromodel Disk — This IBM-PC (or compatible) high density diskette contains the library of LTC op amp SPICE macromodels. The models can be used with any version of SPICE for general analog circuit simulations. The diskette also contains working circuit examples using the models and a demonstration copy of PSPICE™ by MicroSim. Available at no charge

SwitcherCAD™ — The SwitcherCAD program is a powerful PC software tool that aids in the design and optimization of switching regulators. The program can cut days off the design cycle by selecting topologies, calculating operating points and specifying component values and manufacturer's part numbers. 144 page manual included. \$20.00

SwitcherCAD supports the following parts: LT1070 series: LT1070, LT1071, LT1072, LT1074 and LT1076. LT1082. LT1170 series: LT1170, LT1171, LT1172 and LT1176. It also supports: LT1268, LT1269 and LT1507. LT1270 series: LT1270 and LT1271. LT1371 series: LT1371, LT1372, LT1373, LT1375, LT1376 and LT1377.

Micropower SwitcherCAD™ — The MicropowerSCAD program is a powerful tool for designing DC/DC converters based on Linear Technology's micropower switching regulator ICs. Given basic design parameters, MicropowerSCAD selects a circuit topology and offers you a selection of appropriate Linear Technology switching regulator ICs. MicropowerSCAD also performs circuit simulations to select the other components which surround the DC/DC converter. In the case of a battery supply, MicropowerSCAD can perform a battery life simulation. 44 page manual included. \$20.00

MicropowerSCAD supports the following LTC micropower DC/DC converters: LT1073, LT1107, LT1108, LT1109, LT1109A, LT1110, LT1111, LT1173, LTC1174, LT1300, LT1301 and LT1303.

Technical Books

1990 Linear Databook, Vol I — This 1440 page collection of data sheets covers op amps, voltage regulators, references, comparators, filters, PWMs, data conversion and interface products (bipolar and CMOS), in both commercial and military grades. The catalog features well over 300 devices. \$10.00

1992 Linear Databook, Vol II — This 1248 page supplement to the 1990 Linear Databook is a collection of all products introduced in 1991 and 1992. The catalog contains full data sheets for over 140 devices. The 1992 Linear Databook, Vol II is a companion to the 1990 Linear Databook, which should not be discarded. \$10.00

1994 Linear Databook, Vol III — This 1826 page supplement to the 1990 and 1992 Linear Databooks is a collection of all products introduced since 1992. A total of 152 product data sheets are included with updated selection guides. The 1994 Linear Databook Vol III is a companion to the 1990 and 1992 Linear Databooks, which should not be discarded. \$10.00

1995 Linear Databook, Vol IV — This 1152 page supplement to the 1990, 1992 and 1994 Linear Databooks is a collection of all products introduced since 1994. A total of 80 product data sheets are included with updated selection guides. The 1995 Linear Databook Vol IV is a companion to the 1990, 1992 and 1994 Linear Databooks, which should not be discarded. \$10.00

1996 Linear Databook, Vol V — This 1152 page supplement to the 1990, 1992, 1994 and 1995 Linear Databooks is a collection of all products introduced since 1995. A total of 65 product data sheets are included with updated selection guides. The 1996 Linear Databook Vol V is a companion to the 1990, 1992, 1994 and 1995 Linear Databooks, which should not be discarded. \$10.00

1990 Linear Applications Handbook, Volume I — 928 pages full of application ideas covered in depth by 40 Application Notes and 33 Design Notes. This catalog covers a broad range of "real world" linear circuitry. In addition to detailed, systems-oriented circuits, this handbook contains broad tutorial content together with liberal use of schematics and scope photography. A special feature in this edition includes a 22-page section on SPICE macromodels. \$20.00

1993 Linear Applications Handbook, Volume II — Continues the stream of "real world" linear circuitry initiated by the 1990 Handbook. Similar in scope to the 1990 edition, the new book covers Application Notes 40 through 54 and Design Notes 33 through 69. References and articles from non-LTC publications that we have found useful are also included. \$20.00

1997 Linear Applications Handbook, Volume III — This 976 page handbook maintains the practical outlook and tutorial nature of previous efforts, while broadening topic selection. This new book includes Application Notes 55 through 69 and Design Notes 70 through 144. Subjects include switching regulators, measurement and control circuits, filters, video designs, interface, data converters, power products, battery chargers and CCFL inverters. An extensive subject index references circuits in LTC data sheets, design notes, application notes and *Linear Technology* magazines. \$20.00

Interface Product Handbook — This 424 page handbook features LTC's complete line of line driver and receiver products for RS232, RS485, RS423, RS422, V.35 and AppleTalk® applications. Linear's particular expertise in this area involves low power consumption, high numbers of drivers and receivers in one package, mixed RS232 and RS485 devices, 10kV ESD protection of RS232 devices and surface mount packages. Available at no charge

Power Solutions Brochure — This 84 page collection of circuits contains real-life solutions for common power supply design problems. There are over 88 circuits, including descriptions, graphs and performance specifications. Topics covered include battery chargers, PCMCIA power management, microprocessor power supplies, portable equipment power supplies, micropower DC/DC, step-up and step-down switching regulators, off-line switching regulators, linear regulators and switched capacitor conversion. Available at no charge

High Speed Amplifier Solutions Brochure — This 72 page collection of circuits contains real-life solutions for problems that require high speed amplifiers. There are 82 circuits including descriptions, graphs and performance specifications. Topics covered include basic amplifiers, video-related applications circuits, instrumentation, DAC and photodiode amplifiers, filters, variable gain, oscillators and current sources and other unusual application circuits. Available at no charge

Data Conversion Solutions Brochure — This 52 page collection of data conversion circuits, products and selection guides serves as excellent reference for the data acquisition system designer. Over 60 products are showcased, solving problems in low power, small size and high performance data conversion applications—with performance graphs and specifications. Topics covered include ADCs, DACs, voltage references and analog multiplexers. A complete glossary defines data conversion specifications; a list of selected application and design notes is also included. Available at no charge

Telecommunications Solutions Brochure — This 72 page collection of circuits, new products and selection guides covers a wide variety of products targeted for the telecommunications industry. Circuits solving real life problems are shown for central office switching, cellular phone, base station and other telecom applications. New products introduced include high speed amplifiers, A/D converters, power products, interface transceivers and filters. Reference material includes a telecommunications glossary, serial interface standards, protocol information and a complete list of key application notes and design notes. Available at no charge

continued on page 40

Acrobat is a trademark of Adobe Systems, Inc. AppleTalk is a registered trademark of Apple Computer, Inc. PSPICE is a trademark of MicroSim Corp.

Information furnished by Linear Technology Corporation is believed to be accurate and reliable. However, Linear Technology makes no representation that the circuits described herein will not infringe on existing patent rights.

CD-ROM

LinearView — LinearView™ CD-ROM version 2.0 is Linear Technology's latest interactive CD-ROM. It allows you to instantly access thousands of pages of product and applications information, covering Linear Technology's complete line of high performance analog products, with easy-to-use search tools.

The LinearView CD-ROM includes the complete product specifications from Linear Technology's Databook library (Volumes I-V) and the complete Applications Handbook collection (Volumes I-III). Our extensive collection of Design Notes and the complete collection of *Linear Technology* magazine are also included.

A powerful search engine built into the LinearView CD-ROM enables you to select parts by various criteria, such as device parameters, keywords or part numbers. All product categories are represented: data conversion, references, amplifiers, power products, filters and interface circuits. Up-to-date versions of Linear Technology's software design tools, SwitcherCAD,

Micropower SwitcherCAD, FilterCAD, Noise Disk and Spice Macromodel library, are also included. Everything you need to know about Linear Technology's products and applications is readily accessible via LinearView. LinearView 2.0 runs under Windows® 3.1, Windows 95 and Macintosh® System 7.0 or later.

Available at no charge.

World Wide Web Site

Linear Technology Corporation's customers can now quickly and conveniently find and retrieve the latest technical information covering the Company's products on LTC's new internet web site. Located at www.linear-tech.com, this site allows anyone with internet access and a web browser to search through all of LTC's technical publications, including data sheets, application notes, design notes, *Linear Technology* magazine issues and other LTC publications, to find information on LTC parts and applications circuits. Other areas within the site include help, news and information about Linear Technology and its sales offices.

Other web sites usually require the visitor to download large document files to see if they contain the desired information. This is cumbersome and inconvenient. To save you time and ensure that you receive the correct information the first time, the first page of each data sheet, application note and *Linear Technology* magazine is recreated in a fast, download-friendly format. This allows you to determine whether the document is what you need, before downloading the entire file.

The site is searchable by criteria such as part numbers, functions, topics and applications. The search is performed on a user-defined combination of data sheets, application notes, design notes and *Linear Technology* magazine articles. Any data sheet, application note, design note or magazine article can be downloaded or faxed back. (Files are downloaded in Adobe Acrobat™ PDF format; you will need a copy of Acrobat Reader to view or print them. The site includes a link from which you can download this program.)

Acrobat is a trademark of Adobe Systems, Inc.; Windows is a registered trademark of Microsoft Corp.; Macintosh is a registered trademark of Apple Computer, Inc.

World Headquarters

Linear Technology Corporation
1630 McCarthy Boulevard
Milpitas, CA 95035-7417
Phone: (408) 432-1900
FAX: (408) 434-0507

U.S. Area Sales Offices

NORTHEAST REGION

Linear Technology Corporation
3220 Tillman Drive, Suite 120
Bensalem, PA 19020
Phone: (215) 638-9667
FAX: (215) 638-9764

Linear Technology Corporation
266 Lowell St., Suite B-8
Wilmington, MA 01887
Phone: (508) 658-3881
FAX: (508) 658-2701

NORTHWEST REGION

Linear Technology Corporation
1900 McCarthy Blvd., Suite 205
Milpitas, CA 95035
Phone: (408) 428-2050
FAX: (408) 432-6331

SOUTHEAST REGION

Linear Technology Corporation
17000 Dallas Parkway, Suite 219
Dallas, TX 75248
Phone: (972) 733-3071
FAX: (972) 380-5138

Linear Technology Corporation
9430 Research Blvd.
Echelon IV Suite 400
Austin, TX 78759
Phone: (512) 343-3679
FAX: (512) 343-3680

Linear Technology Corporation
Houston, TX 77478
Phone: (972) 733-3071
FAX: (972) 380-5138

Linear Technology Corporation
5510 Six Forks Road, Suite 102
Raleigh, NC 27609
Phone: (919) 870-5106
FAX: (919) 870-8831

CENTRAL REGION

Linear Technology Corporation
2010 E. Algonquin Road, Suite 209
Schaumburg, IL 60173
Phone: (847) 925-0860
FAX: (847) 925-0878

Linear Technology Corporation
Kenosha, WI 53144
Phone: (414) 859-1900
FAX: (414) 859-1974

SOUTHWEST REGION

Linear Technology Corporation
21243 Ventura Blvd., Suite 227
Woodland Hills, CA 91364
Phone: (818) 703-0835
FAX: (818) 703-0517

Linear Technology Corporation
15375 Barranca Parkway, Suite A-211
Irvine, CA 92718
Phone: (714) 453-4650
FAX: (714) 453-4765

International Sales Offices

FRANCE

Linear Technology S.A.R.L.
Immeuble "Le Quartz"
58 Chemin de la Justice
92290 Chatenay Malabry
France
Phone: 33-1-41079555
FAX: 33-1-46314613

GERMANY

Linear Technology GmbH
Oskar-Messter-Str. 24
D-85737 Ismaning
Germany
Phone: 49-89-962455-0
FAX: 49-89-963147

JAPAN

Linear Technology KK
5F NAO Bldg.
1-14 Shin-Ogawa-cho Shinjuku-ku
Tokyo, 162
Japan
Phone: 81-3-3267-7891
FAX: 81-3-3267-8510

KOREA

Linear Technology Korea Co., Ltd
Namsong Building, #403
Itaewon-Dong 260-199
Yongsan-Ku, Seoul 140-200
Korea
Phone: 82-2-792-1617
FAX: 82-2-792-1619

SINGAPORE

Linear Technology Pte. Ltd.
507 Yishun Industrial Park A
Singapore 2776
Phone: 65-753-2692
FAX: 65-754-4113

SWEDEN

Linear Technology AB
Sollentunavägen 63
S-191 40 Sollentuna
Sweden
Phone: (08)-623-1600
FAX: (08)-623-1650

TAIWAN

Linear Technology Corporation
Rm. 602, No. 46, Sec. 2
Chung Shan N. Rd.
Taipei, Taiwan, R.O.C.
Phone: 886-2-521-7575
FAX: 886-2-562-2285

UNITED KINGDOM

Linear Technology (UK) Ltd.
The Coliseum, Riverside Way
Camberley, Surrey GU15 3YL
United Kingdom
Phone: 44-1276-677676
FAX: 44-1276-64851

LINEAR TECHNOLOGY CORPORATION

1630 McCarthy Boulevard
Milpitas, CA 95035-7417
(408) 432-1900 FAX (408) 434-0507
www.linear-tech.com

For Literature Only: 1-800-4-LINEAR

